

SECTION BR
BRAKE SYSTEM

A
B
C
D
E

CONTENTS

PRECAUTION	3	BRAKE TUBE AND HOSE	10	BR
PRECAUTIONS	3	Hydraulic Circuit	10	
Precaution for Supplemental Restraint System (SRS) "AIR BAG" and "SEAT BELT PRE-TENSIONER"	3	FRONT BRAKE	10	G
Precautions For High-Voltage System	3	FRONT BRAKE : Inspection	10	
Precaution for Brake System	3	REAR BRAKE	11	H
Precaution for Procedure without Cowl Top Cover.....	4	REAR BRAKE : Inspection	11	
PREPARATION	5	ON-VEHICLE MAINTENANCE	12	
PREPARATION	5	BRAKE PEDAL	12	I
Special Service Tool	5	Inspection and Adjustment	12	
Commercial Service Tool	5	BRAKE FLUID	14	J
FUNCTION DIAGNOSIS	6	On Board Inspection	14	
NOISE, VIBRATION AND HARSHNESS (NVH) TROUBLESHOOTING	6	Refilling	14	K
NVH Troubleshooting Chart	6	Bleeding Brake System	14	
BASIC INSPECTION	7	ON-VEHICLE REPAIR	19	L
FRONT DISC BRAKE	7	BRAKE PEDAL	19	
BRAKE PAD	7	Exploded View	19	M
BRAKE PAD : Inspection	7	Removal and Installation	19	
DISC ROTOR	7	BRAKE TUBE AND HOSE	21	N
DISC ROTOR : Inspection	7	Hydraulic Circuit	21	
REAR DISC BRAKE	8	FRONT BRAKE	21	O
BRAKE PAD	8	FRONT BRAKE : Removal and Installation	21	
BRAKE PAD : Inspection	8	REAR BRAKE	23	P
DISC ROTOR	8	REAR BRAKE : Removal and Installation	23	
DISC ROTOR : Inspection	8	BRAKE MASTER CYLINDER	25	
BRAKE MASTER CYLINDER	9	Exploded View	25	
On Board Inspection	9	Removal and Installation	25	
		FRONT DISC BRAKE	27	
		BRAKE PAD	27	
		BRAKE PAD : Exploded View	27	
		BRAKE PAD : Removal and Installation	27	
		BRAKE PAD : Brake Burnishing Procedure	29	

BRAKE CALIPER ASSEMBLY	29	BRAKE CALIPER ASSEMBLY : Exploded View ...	39
BRAKE CALIPER ASSEMBLY : Exploded View ...	29	BRAKE CALIPER ASSEMBLY : Disassembly	39
BRAKE CALIPER ASSEMBLY : Removal and In-		BRAKE CALIPER ASSEMBLY : Inspection After	
stallation	30	Disassembly	40
REAR DISC BRAKE	32	BRAKE CALIPER ASSEMBLY : Assembly	40
BRAKE PAD	32	REAR DISC BRAKE	42
BRAKE PAD : Exploded View	32	BRAKE CALIPER ASSEMBLY	42
BRAKE PAD : Removal and Installation	32	BRAKE CALIPER ASSEMBLY : Exploded View ...	42
BRAKE CALIPER ASSEMBLY	34	BRAKE CALIPER ASSEMBLY : Disassembly	42
BRAKE CALIPER ASSEMBLY : Exploded View ...	34	BRAKE CALIPER ASSEMBLY : Inspection After	
BRAKE CALIPER ASSEMBLY : Removal and In-		Disassembly	43
stallation	34	BRAKE CALIPER ASSEMBLY : Assembly	43
DISASSEMBLY AND ASSEMBLY	37	SERVICE DATA AND SPECIFICATIONS	
BRAKE MASTER CYLINDER	37	(SDS)	45
Exploded View	37	SERVICE DATA AND SPECIFICATIONS	
Disassembly and Assembly	37	(SDS)	45
FRONT DISC BRAKE	39	General Specifications	45
BRAKE CALIPER ASSEMBLY	39	Brake Pedal	45
		Front Disc Brake	45
		Rear Disc Brake	

PRECAUTIONS

< PRECAUTION >

PRECAUTION

PRECAUTIONS

Precaution for Supplemental Restraint System (SRS) "AIR BAG" and "SEAT BELT PRE-TENSIONER"

INFOID:000000005804839

The Supplemental Restraint System such as "AIR BAG" and "SEAT BELT PRE-TENSIONER", used along with a front seat belt, helps to reduce the risk or severity of injury to the driver and front passenger for certain types of collision. This system includes seat belt switch inputs and dual stage front air bag modules. The SRS system uses the seat belt switches to determine the front air bag deployment, and may only deploy one front air bag, depending on the severity of a collision and whether the front occupants are belted or unbelted. Information necessary to service the system safely is included in the SR and SB section of this Service Manual.

WARNING:

- To avoid rendering the SRS inoperative, which could increase the risk of personal injury or death in the event of a collision which would result in air bag inflation, all maintenance must be performed by an authorized NISSAN/INFINITI dealer.
- Improper maintenance, including incorrect removal and installation of the SRS, can lead to personal injury caused by unintentional activation of the system. For removal of Spiral Cable and Air Bag Module, see the SR section.
- Do not use electrical test equipment on any circuit related to the SRS unless instructed to in this Service Manual. SRS wiring harnesses can be identified by yellow and/or orange harnesses or harness connectors.

PRECAUTIONS WHEN USING POWER TOOLS (AIR OR ELECTRIC) AND HAMMERS

WARNING:

- When working near the Airbag Diagnosis Sensor Unit or other Airbag System sensors with the Ignition ON or engine running, DO NOT use air or electric power tools or strike near the sensor(s) with a hammer. Heavy vibration could activate the sensor(s) and deploy the air bag(s), possibly causing serious injury.
- When using air or electric power tools or hammers, always switch the Ignition OFF, disconnect the battery, and wait at least 3 minutes before performing any service.

Precautions For High-Voltage System

INFOID:000000005440545

Refer to [GI-24. "Precautions For High-Voltage System"](#).

Precaution for Brake System

INFOID:000000005440546

- Clean dust on front brake and rear brake with a vacuum dust collector. Do not blow with compressed air.
- Recommended fluid is brake fluid "DOT 3".
- Never reuse drained brake fluid.
- Be careful not to splash brake fluid on painted areas; it may cause paint damage. If brake fluid is splashed on painted areas, wash it away with water immediately.
- Use clean brake fluid, to clean or wash all parts of master cylinder and disc brake caliper, etc.
- Never use mineral oils such as gasoline or kerosene. They will ruin rubber parts of the hydraulic system.
- Use flare nut torque wrench when installing brake tube.
- When installing brake tube and hose, be sure to check torque.
- Before working, turn ignition switch OFF and disconnect connectors of ABS actuator and electric unit (control unit) or battery cable from the negative terminal.
- Burnish the brake contact surfaces after refinishing or replacing rotors, after replacing pads, or if a soft pedal occurs at very low mileage. Refer to [BR-29. "BRAKE PAD : Brake Burnishing Procedure"](#).

WARNING:

- Clean brake pads and shoes with a waste cloth, then wipe with a dust collector.

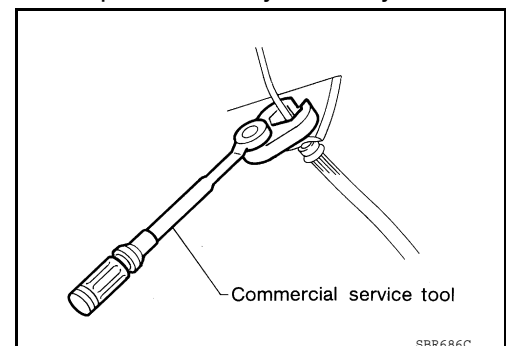

PRECAUTIONS

< PRECAUTION >

Precaution for Procedure without Cowl Top Cover

INFOID:000000005440547

When performing the procedure after removing cowl top cover, cover the lower end of windshield with urethane, etc.

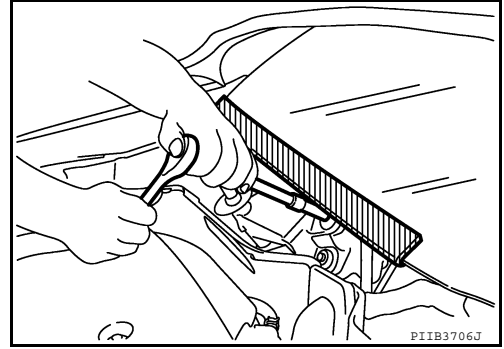

PREPARATION

< PREPARATION >

PREPARATION

PREPARATION

Special Service Tool

INFOID:000000005440549

The actual shapes of Kent-Moore tools may differ from those of special service tools illustrated here.

Tool number (Kent-Moore No.) Tool name	Description
— (J-46532) Brake and clutch pedal height measurement tool	Measuring brake pedal height
38-PFM90.5 (—) Pro-Cut PFM 90 On-Car Brake Lathe	Turning rotors

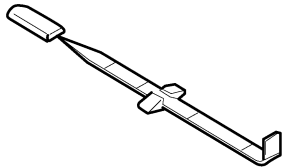

LFIA0227E

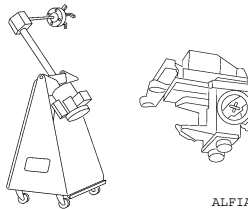

ALFIA0092ZZ

Commercial Service Tool

INFOID:000000005440550

Tool name	Description
1. Flare nut crowfoot 2. Torque wrench	Removing and installing brake tube and hose flare nuts a: 10 mm (0.39 in) / 12 mm (0.47 in)
Power tool	Removing nuts, bolts and screws

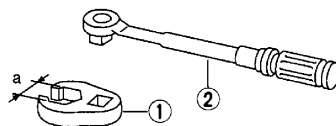

NT360



PIIB1407E

NOISE, VIBRATION AND HARSHNESS (NVH) TROUBLESHOOTING

< FUNCTION DIAGNOSIS >

FUNCTION DIAGNOSIS

NOISE, VIBRATION AND HARSHNESS (NVH) TROUBLESHOOTING

NVH Troubleshooting Chart

INFOID:000000005440551

Use the chart below to help you find the cause of the symptom. If necessary, repair or replace these parts.

Symptom	Possible cause and SUSPECTED PARTS		Reference page																	
	Noise	Shimmy, Shudder	Pads - damaged	Pads - uneven wear	Shims damaged	Rotor imbalance	Rotor damage	Rotor runout	Rotor deformation	Rotor deflection	Rotor rust	Rotor thickness variation	Drum out of round	WHEEL HUB	SUSPENSION	AXLE	TIRES	ROAD WHEEL	DRIVE SHAFT	STEERING
			×	×	×									×	×	×	×	×	×	×
						×	×	×	×	×	×	×		×	×	×	×	×	×	×
															×	×	×	×		×

×: Applicable

FRONT DISC BRAKE

< BASIC INSPECTION >

BASIC INSPECTION

FRONT DISC BRAKE

BRAKE PAD

BRAKE PAD : Inspection

INFOID:000000005440552

PAD WEAR

Check pad thickness from an inspection hole on cylinder body.
Check using a scale if necessary.

Standard thickness : Refer to [BR-45, "Front Disc Brake"](#).

Wear limit thickness : Refer to [BR-45, "Front Disc Brake"](#).

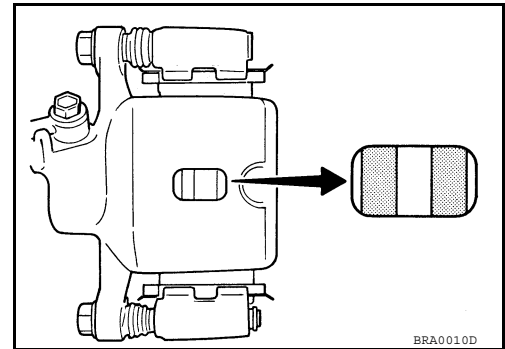

DISC ROTOR

DISC ROTOR : Inspection

INFOID:000000005440553

VISUAL

Check surface of disc rotor for uneven wear, cracks, and serious damage. Replace as necessary.

RUNOUT

1. Attach disc rotor to wheel hub using wheel nuts at two or more positions.
2. Inspect runout using a dial gauge. Set dial gauge to measure at 10 mm (0.39 in) inside the disc edge.

Maximum runout : Refer to [BR-45, "Front Disc Brake"](#).
(with it attached to the vehicle)

NOTE:

Before measuring, make sure that wheel bearing axial end play is within the specification. Refer to [FAX-5, "Inspection"](#).

3. When runout exceeds limit value, rotate mounting position of disc rotor by one hole. And then find a position of the minimum value for runout.
4. If runout is outside the specified value after performing the above operation, turn the disc rotor using Tool.

Tool number : 38-PFM90.5

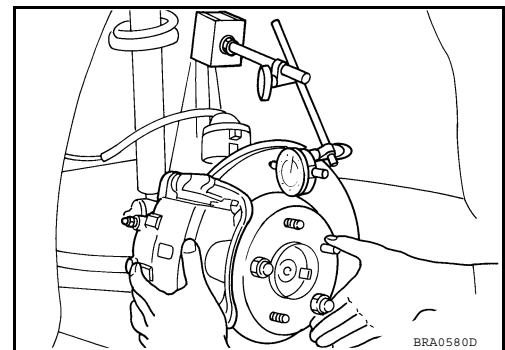

THICKNESS

Check thickness of the disc rotor using a micrometer. Replace disc rotor if thickness is under the wear limit.

Standard thickness : Refer to [BR-45, "Front Disc Brake"](#).

Wear limit thickness : Refer to [BR-45, "Front Disc Brake"](#).

Thickness variation (measured at 8 positions) : Refer to [BR-45, "Front Disc Brake"](#).

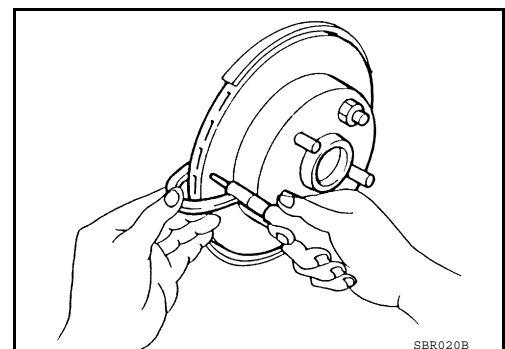

A
B
C
D
E
BR
G
H
I
J
K
L
M
N
O
P

REAR DISC BRAKE

< BASIC INSPECTION >

REAR DISC BRAKE BRAKE PAD

BRAKE PAD : Inspection

INFOID:000000005440554

PAD WEAR

Check pad thickness from an inspection hole on cylinder body.
Check using a scale if necessary.

- Standard thickness** : Refer to [BR-46, "Rear Disc Brake"](#).
- Wear limit thickness** : Refer to [BR-46, "Rear Disc Brake"](#).

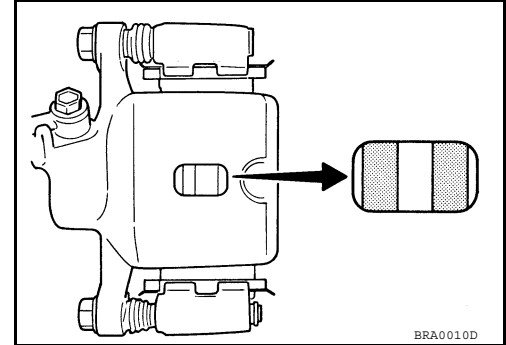

DISC ROTOR

DISC ROTOR : Inspection

INFOID:000000005440555

VISUAL

Check surface of disc rotor for uneven wear, cracks, and serious damage. Replace as necessary.

RUNOUT

1. Attach disc rotor to wheel hub using wheel nuts at two or more positions.
2. Inspect runout using dial gauge. Set dial gauge to measure at 10 mm (0.39 in) inside disc edge.

Maximum runout : Refer to [BR-46, "Rear Disc Brake"](#).
(with it attached to the vehicle)

NOTE:

Before measuring, make sure that wheel bearing axial end play is within the specification. Refer to [FAX-5, "Inspection"](#).

3. When runout exceeds limit value, rotate mounting position of disc rotor by one hole. And then find a position of the minimum value for runout.
4. If runout is outside the specified value after performing the above operation, turn the disc rotor using Tool.

Tool number : 38-PFM90.5

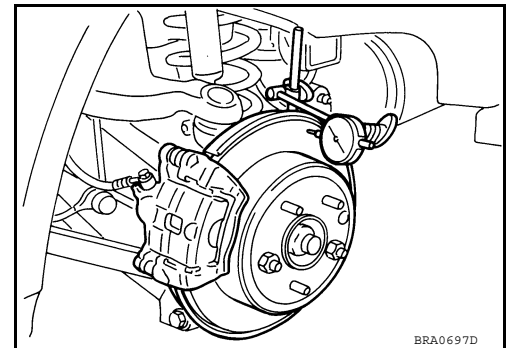

THICKNESS

Check the thickness of the disc rotor using a micrometer. Replace disc rotor if the thickness is under the wear limit.

- Standard thickness** : Refer to [BR-46, "Rear Disc Brake"](#).
- Wear limit thickness** : Refer to [BR-46, "Rear Disc Brake"](#).
- Thickness variation (measured at 8 positions)** : Refer to [BR-46, "Rear Disc Brake"](#).

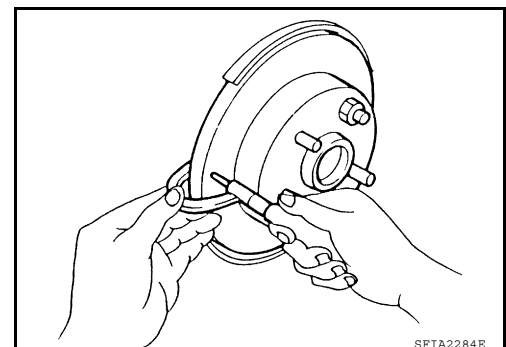

BRAKE MASTER CYLINDER

< BASIC INSPECTION >

BRAKE MASTER CYLINDER

On Board Inspection

INFOID:000000005440556

LEAK INSPECTION

Check for leaks at master cylinder attachment point, reservoir tank hose connection, and brake pipe and hose connections.

A

B

C

D

E

BR

G

H

I

J

K

L

M

N

O

P

BRAKE TUBE AND HOSE

< BASIC INSPECTION >

BRAKE TUBE AND HOSE

Hydraulic Circuit

INFOID:000000005440557

Four Channel Hydraulic Circuit

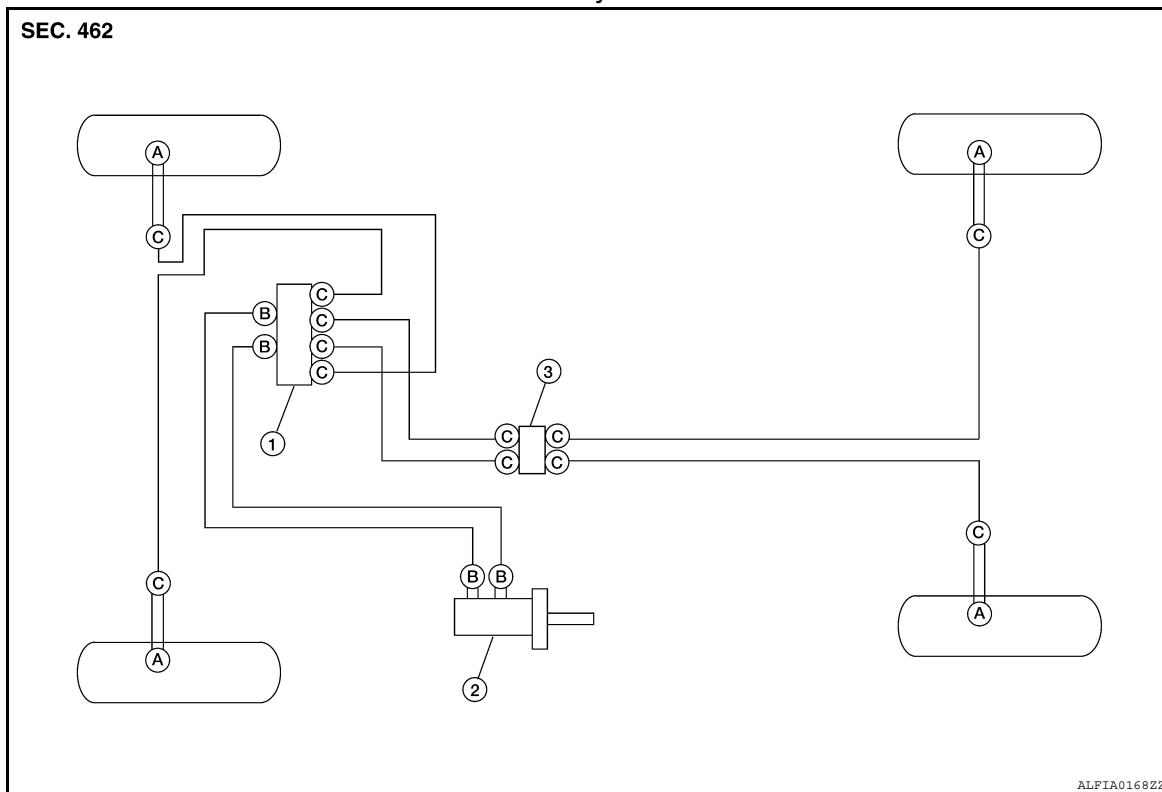

- | | | |
|--|---|---|
| 1. ABS actuator and electric unit (control unit) | 2. Master cylinder | 3. Connector |
| A. Union bolt
18.2 N·m (1.9 kg·m, 13 ft·lb) | B. Flare nut M12
18.2 N·m (1.9 kg·m, 13 ft·lb) | C. Flare nut M10
16.2 N·m (1.7 kg·m, 12 ft·lb) |

CAUTION:

- All hoses and piping (tubes) must be free from excessive bending, twisting and pulling.
- Make sure there is no interference with other parts when turning steering both clockwise and counterclockwise.
- The brake piping is an important safety part. If a brake fluid leak is detected, always disassemble the parts. Replace applicable part with a new one, if necessary.
- Be careful not to splash brake fluid on painted areas; it may cause paint damage. If brake fluid is splashed on painted areas, wash it away with water immediately.
- Do not bend or twist brake hose sharply, or strongly pull it.
- When removing components, cover connections so that no dirt, dust, or other foreign matter gets in.
- Do not reuse drained brake fluid.
- After installation of the ABS actuator and electric unit (control unit), refill brake system with new brake fluid. Then bleed the air from the system. Refer to [BR-14, "Bleeding Brake System"](#).

FRONT BRAKE

FRONT BRAKE : Inspection

INFOID:000000005440558

INSPECTION AFTER REMOVAL

CAUTION:

Brake tubes and hoses are important safety parts. Always disassemble the parts and retighten their fittings, if a brake fluid leak is detected. Replace applicable part with a new one, if damaged part is detected.

1. Check brake tubes and hoses, and all connections for fluid leaks, damage, twists, deformation, contacts with other parts, and loose connections. Replace any damaged parts.

BRAKE TUBE AND HOSE

< BASIC INSPECTION >

2. While depressing brake pedal under a force of 785 N (80 kg-f, 177 lb-f) with engine running for approximately 5 seconds, then check each part for fluid leakage.

A

REAR BRAKE

REAR BRAKE : Inspection

INFOID:000000005440559

B

INSPECTION AFTER REMOVAL

CAUTION:

Brake tubes and hoses are important safety parts. Always disassemble the parts and retighten their fittings, if a brake fluid leak is detected. Replace applicable part with a new one, if damaged part is detected.

C

1. Check brake tubes and hoses, and all connections for fluid leaks, damage, twists, deformation, contacts with other parts, and loose connections. Replace any damage parts.
2. While depressing brake pedal under a force of 785 N (80 kg-f, 177 lb-f) with engine running for approximately 5 seconds, then check each part for fluid leakage.

D

E

BR

G

H

I

J

K

L

M

N

O

P

BRAKE PEDAL

< ON-VEHICLE MAINTENANCE >

ON-VEHICLE MAINTENANCE

BRAKE PEDAL

Inspection and Adjustment

INFOID:000000005440560

INSPECTION

1. Inspect the brake pedal free height (H) from the floor using Tool at a 90° angle to the floor as shown.

Tool number : — (J-46532)

2. Adjust the brake pedal height to specifications.

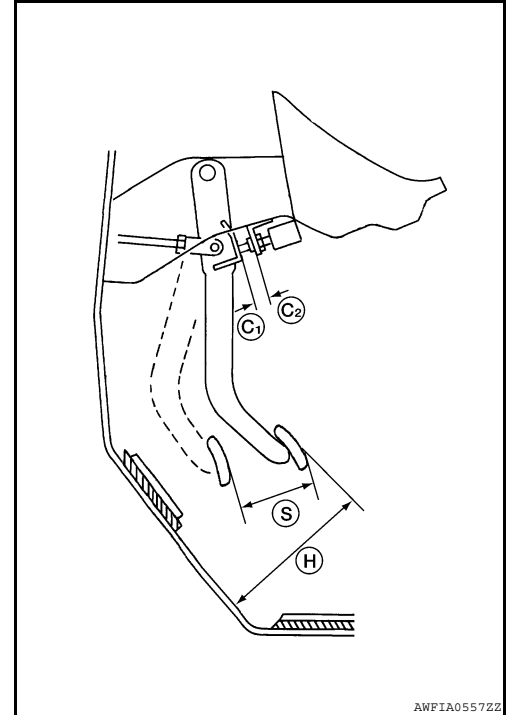

AWFIA0557ZZ

Brake Pedal Specifications

H	Brake pedal height (from dash lower panel top surface)	Refer to BR-45, "Brake Pedal" .
S	Brake pedal full stroke	Refer to BR-45, "Brake Pedal" .
C1, C2	Clearance between bracket and threaded end of the stop lamp switch and ASCD cancel switch	Refer to BR-45, "Brake Pedal" .

ADJUSTMENT

BRAKE PEDAL

< ON-VEHICLE MAINTENANCE >

1. Loosen the stop lamp switch and ASCD cancel switch by turning it counterclockwise by 45°.
2. Loosen lock nut (A) on the input rod, then turn input rod to adjust the brake pedal height to specification, and tighten lock nut (A).

Lock nut torque Refer to [BR-25. "Exploded View"](#)

CAUTION:

Make sure the threaded end of input rod stays inside clevis.

3. With the pedal pulled up and held by hand, press the stop lamp switch and ASCD cancel switch until the threaded end contacts the stopper.
4. With the threaded end of the stop lamp switch and ASCD cancel switch contacting the bracket, rotate the switch clockwise by 45° to secure.

CAUTION:

Make sure that the clearance (C) between bracket and end of stop lamp switch and brake switch is within the standard. Refer to [BR-12. "Inspection and Adjustment"](#).

5. Check the brake pedal for smooth operation.

CAUTION:

Make sure that stop lamps are off when the brake pedal is released.

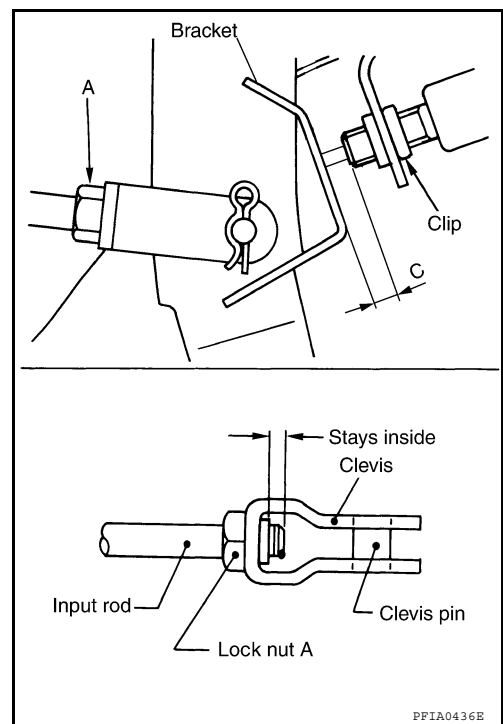

A
B
C
D
E
BR
G
H
I
J
K
L
M
N
O
P

BRAKE FLUID

< ON-VEHICLE MAINTENANCE >

BRAKE FLUID

On Board Inspection

INFOID:000000005440561

BRAKE FLUID LEVEL

- Check that the brake fluid level in reservoir tank is within the specified range between the MAX and MIN lines as shown.
- Visually check around the reservoir tank for fluid leaks.
- If the fluid level is excessively low, check the brake system for leaks.
- Release the parking brake and check if the brake warning lamp goes off. If not, check brake system for fluid leaks.

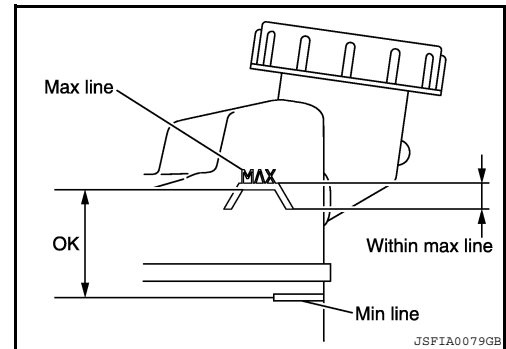

BRAKE LINE

CAUTION:

If leakage occurs around joints, retighten or, if necessary, replace damaged parts.

1. Check brake lines (tubes and hoses) for cracks, deterioration or other damage. Replace any damaged parts.
2. Check for oil leakage by fully depressing brake pedal while the car is ON.

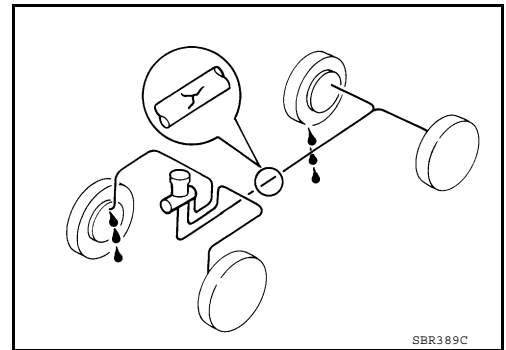

Refilling

INFOID:000000005440562

REFILLING

Make sure there is no foreign material in the reservoir tank, and refill with new brake fluid to the proper level.

CAUTION:

- Refill with new brake fluid "DOT 3".
- Never reuse drained brake fluid.

Bleeding Brake System

INFOID:000000005440563

CAUTION:

- If any DTC is indicated, erase the indicated DTC.
- After the procedure of air bleed, perform initialization of linear solenoid valve. Refer to [BRC-7, "PERFORM INITIALIZATION OF LINEAR SOLENOID VALVE AND CALIBRATION : Description"](#).

NOTE:

The brake warning buzzer may be activated during the air bleed procedure. The work can be continued, as it is normal.

AIR RELEASE OF STATIC PRESSURE SYSTEM (FRONT WHEEL)

CAUTION:

- Monitor the fluid level in the reservoir tank during the air bleeding.
- Always use new brake fluid for refilling. Never reuse the drained brake fluid.

1. Turn ignition switch OFF.
2. Connect CONSULT-III.
3. Turn ignition switch (READY).

BRAKE FLUID

< ON-VEHICLE MAINTENANCE >

4. When performing air bleed of the static pressure system and suction drain system, remove 2 relays for brake actuator motor beforehand. A
5. Connect a vinyl tube to the bleeder valve of the front brake.
6. When performing air bleed, following conditions are required. B
 - ABS relay No.1 and No.2: ON
 - Parking brake: ON
 - Shift position: P range
 - Vehicle speed: 0 km/h (0 MPH) C
 - Normal power supply voltage
 - Normal communication with HV
 - No failure of brake system (except following items) D
 - Motor relay
 - Accumulator
 - Fluid level switch
 - Calibration for each sensors and linear solenoid
 - Test mode diag code
7. Select "AIR REL INHIBIT" in "ACTIVE TEST".
8. Loosen the bleeder valve and bleed air with the brake pedal depressed. BR
NOTE:
Air bleeding is allowed to start from either right or left.
9. After a complete air bleeding, tighten bleeder valve to the specified torque. G
10. Check that the fluid level in the reservoir tank is within the specified range after air bleeding.

AIR RELEASE OF SUCTION DRAIN SYSTEM

CAUTION:

- Monitor the fluid level in the reservoir tank during the air bleeding. H
- Perform the air bleed procedure within 30 seconds after the transmission of the signal from CONSULT-III. When the air bleed is performed afterward, the re-transmission of the signal from CONSULT-III is needed. I

NOTE:

Air bleed from the bleeder valve is not necessary since this operation is to return brake fluid (air).

1. Turn ignition switch OFF. J
2. Connect CONSULT-III.
3. Turn ignition switch (READY).
4. When performing air bleed, following conditions are required. K
 - ABS relay No.1 and No.2: ON
 - Parking brake: ON
 - Shift position: P range
 - Vehicle speed: 0 km/h (0 MPH) L
 - Normal power supply voltage
 - Normal communication with HV
 - No failure of brake system (except following items) M
 - Motor relay
 - Accumulator
 - Fluid level switch
 - Calibration for each sensors and linear solenoid
 - Test mode diag code
5. Select "AIR REL DRAIN" in "ACTIVE TEST". O
6. Step on the brake pedal and return brake fluid to reservoir tank.
7. Ensure that no air (bubble) is contained in the brake fluid circulated from reservoir tank. P

AIR RELEASE OF REAR WHEEL SYSTEM

CAUTION:

- Monitor the fluid level in the reservoir tank during the air bleeding.
- Always use new brake fluid for refilling. Never reuse the drained brake fluid.

1. Turn ignition switch OFF.
2. Connect 2 motor relays.
3. Connect CONSULT-III.

BRAKE FLUID

< ON-VEHICLE MAINTENANCE >

4. Turn ignition switch (READY).
NOTE:
If CONSULT-III is freezed, erase the DTC.
5. Confirm accumulator pressure level by using "DATA MONITOR" in CONSULT-III.
 - a. Select "ACC PRESS SEN" in "DATA MONITOR".
 - b. Ensure that this voltage is over 3.42 V.
 - c. If voltage is under 3.42 V, then step on the brake pedal several time.
6. When performing air bleed, following conditions must be met.
 - ABS relay No.1 and No.2: ON
 - Parking brake: ON
 - Shift position: P range
 - Vehicle speed: 0 km/h (0 MPH)
 - Normal power supply voltage
 - Normal communication with HV
 - ABS motor relay No.1 and No.2 are set
 - No failure of brake system (except following items)
 - Motor relay
 - Accumulator
 - Fluid level switch
 - Calibration for each sensors and linear solenoid
 - Test mode diag code
7. Connect a vinyl tube to the bleeder valve of the rear brake.
8. Select "AIR REL INHIBIT" in "ACTIVE TEST".
9. Loosen the bleeder valve and bleed air with the brake pedal depressed.
10. Ensure that there is no air leakage from the bleeder.
11. After a complete air bleeding, tighten bleeder valve to the specified torque.
12. Check that the fluid level in the reservoir tank is within the specified range after air bleeding.

AIR RELEASE OF POWER SUPPLY SYSTEM

CAUTION:

- **Monitor the fluid level in the reservoir tank during the air bleeding.**
- **Always use new brake fluid for refilling. Never reuse the drained brake fluid.**
- **Perform the air bleed procedure within 10 seconds after the transmission of the signal from CONSULT-III. When the air bleed is performed afterward, the re-transmission of the signal from CONSULT-III is needed.**

NOTE:

- No need to step on the brake pedal.
 - Air bleeding is necessary for the front left brake only.
1. Turn ignition switch OFF.
 2. Connect CONSULT-III.
 3. Turn ignition switch (READY).
 4. Connect a vinyl tube to the bleeder valve of the front left brake.
 5. When performing air bleed, following conditions must be met.
 - ABS relay No.1 and No.2: ON
 - Parking brake: ON
 - Shift position: P range
 - Vehicle speed: 0 km/h (0 MPH)
 - Normal power supply voltage
 - Normal communication with HV
 - ABS motor relay No.1 and No.2 are set
 - No failure of brake system (except following items)
 - Motor relay
 - Accumulator
 - Fluid level switch
 - Calibration for each sensors and linear solenoid
 - Test mode diag code
 6. Select "AIR REL PWR SPLY 2" in "ACTIVE TEST".

BRAKE FLUID

< ON-VEHICLE MAINTENANCE >

7. Loosen the bleeder valve.
8. Ensure that there is no air leakage from the bleeder.
9. After a complete air bleeding, tighten bleeder valve to the specified torque.

AIR RELEASE OF STROKE SIMULATOR SYSTEM

Air Bleed of Stroke Simulator System 1

CAUTION:

Perform the air bleed procedure within 30 seconds after the transmission of the signal from CONSULT-III. When the air bleed is performed afterward, the re-transmission of the signal from CONSULT-III is needed.

NOTE:

- Air bleed from the bleeder is not necessary in this stage.
 - This process is performed to send air contained in the stroke simulator to piping. Pedal operation only and no need of air bleed from the bleeder.
1. Turn ignition switch OFF.
 2. Connect CONSULT-III.
 3. Turn ignition switch (READY).
 4. When performing air bleed, following conditions must be met.
 - ABS relay No.1 and No.2: ON
 - Parking brake: ON
 - Shift position: P range
 - Vehicle speed: 0 km/h (0 MPH)
 - Normal power supply voltage
 - Normal communication with HV
 - ABS motor relay No.1 and No.2 are set
 - No failure of brake system (except following items)
 - Motor relay
 - Accumulator
 - Fluid level switch
 - Calibration for each sensors and linear solenoid
 - Test mode diag code
 5. Select "AIR REL STROKE SIM" in "ACTIVE TEST".
 6. Step on the brake pedal 20 times with its stroke fully within continuously 20 to 30 seconds.

Air Release of Stroke Simulator System 2

NOTE:

Air bleeding is necessary for the front left brake only.

1. Connect a vinyl tube to the bleeder valve of the front left brake.
2. When performing air bleed, following conditions must be met.
 - ABS relay No.1 and No.2: ON
 - Parking brake: ON
 - Shift position: P range
 - Vehicle speed: 0 km/h (0 MPH)
 - Normal power supply voltage
 - Normal communication with HV
 - ABS motor relay No.1 and No.2 are set
 - No failure of brake system (except following items)
 - Motor relay
 - Accumulator
 - Fluid level switch
 - Calibration for each sensors and linear solenoid
 - Test mode diag code
3. Select "AIR REL INHIBIT" in "ACTIVE TEST".
4. Loosen the bleeder valve and bleed air with the brake pedal depressed.
5. Ensure that there is no air from the bleeder.
6. Tighten the bleeder valve to the specified torque.

BRAKE FLUID

< ON-VEHICLE MAINTENANCE >

7. Return to previous step "Air Release of Stroke Simulator System 1". Repeat "Air Release of Stroke Simulator System 1" and "Air Release of Stroke Simulator System 2" at least 3 times.

AIR RELEASE OF HIGH-PRESSURE LINE

CAUTION:

Be careful with fluid level in the reservoir tank because a large amount of brake fluid flows back to the reservoir tank.

NOTE:

Air bleed from the bleeder is not necessary in this stage.

1. Turn ignition switch OFF.
2. Connect CONSULT-III.
3. Turn ignition switch (READY).
4. When performing air bleed, following conditions must be met.
 - ABS relay No.1 and No.2: ON
 - Parking brake: ON
 - Shift position: P range
 - Vehicle speed: 0 km/h (0 MPH)
 - Normal power supply voltage
 - Normal communication with HV
 - ABS motor relay No.1 and No.2 are set
 - No failure of brake system (except following items)
 - Motor relay
 - Accumulator
 - Fluid level switch
 - Calibration for each sensors and linear solenoid
 - Test mode diag code
5. Select "ACC 0 DOWN" in "ACTIVE TEST".

NOTE:

Return air remaining in the high-pressure line to reservoir tank and open atmosphere.

6. Repeat 5 times to ensure the circulation of brake fluid since visual judgment of completion is difficult.
7. Fill the brake fluid to the MAX line after completing this operation, with "ACC 0 DOWN" condition.

BRAKE PEDAL

< ON-VEHICLE REPAIR >

ON-VEHICLE REPAIR

BRAKE PEDAL

Exploded View

INFOID:000000005440564

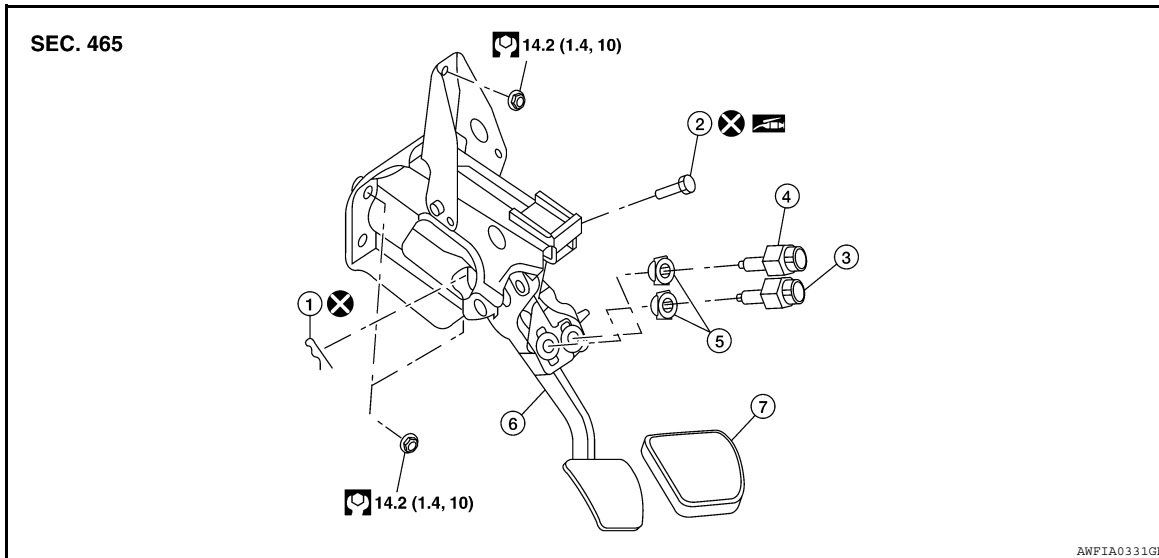

- | | | |
|-----------------------|---------------|-------------------------|
| 1. Snap pin | 2. Clevis pin | 3. Stop lamp switch |
| 4. ASCD cancel switch | 5. Clip | 6. Brake pedal assembly |
| 7. Brake pedal pad | | |

NOTE:

The clevis pin must be installed from the right side as shown above.

Removal and Installation

INFOID:000000005440565

CAUTION:

When the brake pedal position moves after the replacement of stop lamp switch, the replacement of brake pedal or brake pedal height adjustment, measure the zero-point voltage of the brake stroke sensor and confirm that the value is within the normal range. If the value is out of normal range, perform the adjustment of the brake stroke sensor. Refer to [BRC-9, "PERFORM ADJUSTMENT OF STROKE SENSOR : Special Repair Requirement"](#).

REMOVAL

1. Remove the instrument lower cover (LH) and lower knee protector (LH). Refer to [IP-10, "Exploded View"](#).
2. Remove the console side finisher (LH). Refer to [IP-10, "Exploded View"](#).
3. Remove the accelerator pedal. Refer to [ACC-3, "Removal and Installation"](#).
4. Disconnect the stop lamp switch and ASCD cancel switch connector.
5. Remove the stop lamp switch and ASCD cancel switch from the brake pedal assembly.
6. Remove the brake stroke sensor. Refer to [BRC-205, "Removal and Installation"](#).
7. Remove the snap pin and clevis pin to disconnect the brake booster clevis from the brake pedal assembly.
8. Remove the brake booster clevis from the input rod.
9. Disconnect the steering column assembly pinch bolt to position the steering column assembly aside. Refer to [ST-8, "Exploded View"](#).
10. Remove the six brake pedal assembly nuts.
11. Remove the brake pedal assembly from vehicle.

INSTALLATION

Installation is in the reverse order of removal.

- Tightening torque for the lock nut is referred to in [BR-12, "Inspection and Adjustment"](#).

BRAKE PEDAL

< ON-VEHICLE REPAIR >

- Adjust the brake pedal height after installing the brake pedal assembly. Refer to [BR-12, "Inspection and Adjustment"](#).

CAUTION:

Do not reuse the snap pin and clevis pin.

BRAKE TUBE AND HOSE

< ON-VEHICLE REPAIR >

BRAKE TUBE AND HOSE

Hydraulic Circuit

INFOID:000000005440566

Four Channel Hydraulic Circuit

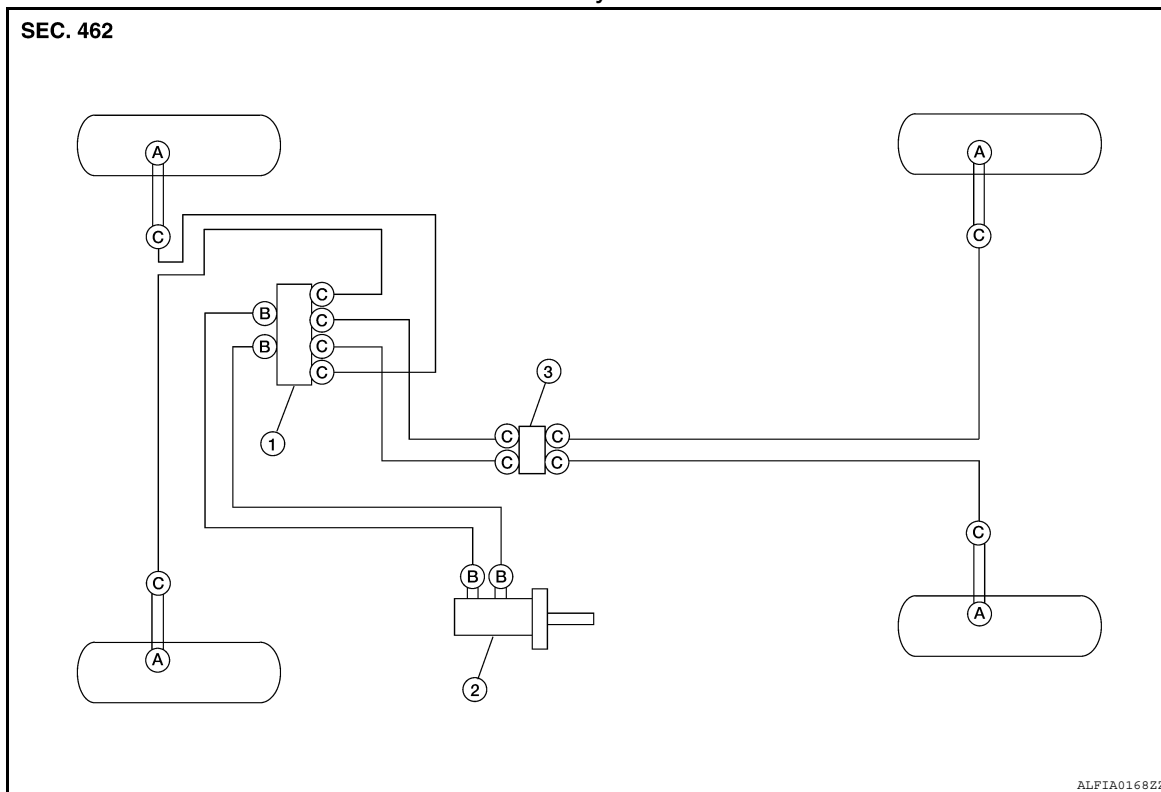

- | | | |
|--|---|---|
| 1. ABS actuator and electric unit (control unit) | 2. Master cylinder | 3. Connector |
| A. Union bolt
18.2 N·m (1.9 kg-m, 13 ft-lb) | B. Master cylinder steel line and rubber hose
Flare nut M12
18.2 N·m (1.9 kg-m, 13 ft-lb) | C. Flare nut M10
16.2 N·m (1.7 kg-m, 12 ft-lb) |

CAUTION:

- All hoses and piping (tubes) must be free from excessive bending, twisting and pulling.
- Make sure there is no interference with other parts when turning steering both clockwise and counterclockwise.
- The brake piping is an important safety part. If a brake fluid leak is detected, always disassemble the parts. Replace applicable part with a new one, if necessary.
- Be careful not to splash brake fluid on painted areas; it may cause paint damage. If brake fluid is splashed on painted areas, wash it away with water immediately.
- Do not bend or twist brake hose sharply, or strongly pull it.
- When removing components, cover connections so that no dirt, dust, or other foreign matter gets in.
- Do not reuse drained brake fluid.
- After installation of the ABS actuator and electric unit (control unit), refill brake system with new brake fluid. Then bleed the air from the system. Refer to [BR-14, "Bleeding Brake System"](#).

FRONT BRAKE

FRONT BRAKE : Removal and Installation

INFOID:000000005440567

REMOVAL

CAUTION:

- Be careful not to splash brake fluid on painted areas; it may cause paint damage. If brake fluid is splashed on painted areas, wash it away with water immediately.
- Cover the open end of brake tubes and hoses when disconnecting to prevent entrance of dirt.

BRAKE TUBE AND HOSE

< ON-VEHICLE REPAIR >

1. Drain the brake fluid. Refer to [BR-14. "Bleeding Brake System"](#).
2. Disconnect the brake hose from brake tube, using a flare nut wrench and then remove the lock plate.

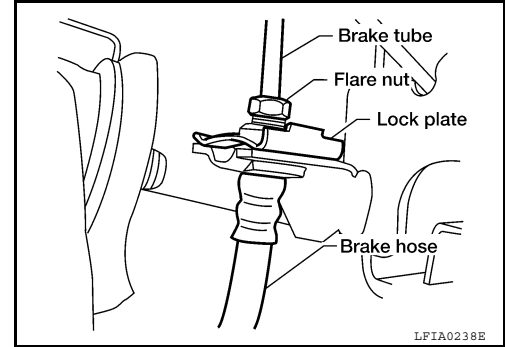

3. Remove the union bolt (A) and remove brake hose from caliper assembly. Discard the copper washers.
 - Protrusions (B)**CAUTION:**
Do not reuse the copper washers.
4. Remove the brake hose.

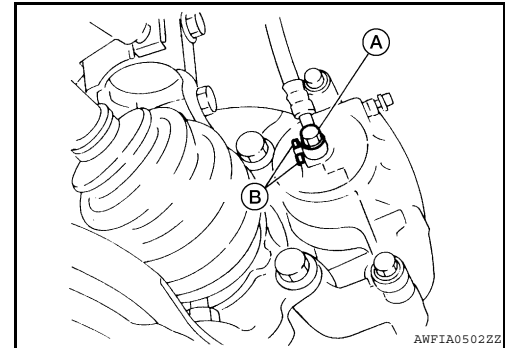

INSTALLATION

CAUTION:

- All brake hoses and tubes must be free from excessive bending, twisting and pulling.
- Make sure that there is no interference with other parts when turning steering both clockwise and counterclockwise.
- Brake tubes and hoses are an important safety part. Always disassemble the parts and retighten their fittings, if a brake fluid leak is detected. Replace applicable part with a new one, if damaged part is detected.
- Be careful not to splash brake fluid on painted areas; it may cause paint damage. If brake fluid is splashed on painted areas, wash it away with water immediately.
- Refill with new brake fluid "DOT 3".
- Never reuse drained brake fluid.

1. Assemble the union bolt and new copper washers on the brake hose.

CAUTION:

Do not reuse the copper washers.

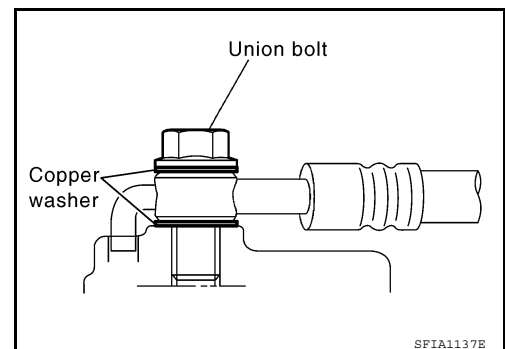

BRAKE TUBE AND HOSE

< ON-VEHICLE REPAIR >

2. Install brake hose by aligning the brake hose with the protrusion (B) on brake caliper assembly as shown. Tighten union bolt (A) to the specified torque.

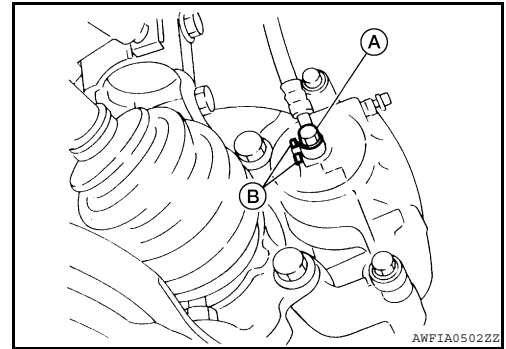

3. Connect brake hose to brake tube, partially tighten flare nut by hand as much as possible, then secure it to the bracket with lock plate.
4. Using a flare nut torque wrench, tighten flare nut to the specified torque.
5. Refill brake fluid and bleed air. Refer to [BR-14. "Bleeding Brake System"](#).

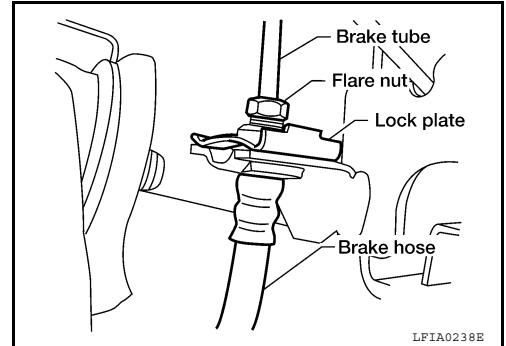

REAR BRAKE

REAR BRAKE : Removal and Installation

INFOID:000000005440568

REMOVAL

CAUTION:

- Be careful not to splash brake fluid on painted areas; it may cause paint damage. If brake fluid is splashed on painted areas, wash it away with water immediately.
- Cover the open end of brake tubes and hoses when disconnecting to prevent entrance of dirt.

1. Drain the brake fluid. Refer to [BR-14. "Bleeding Brake System"](#).
2. Disconnect the brake hose from brake tube, using a flare nut wrench and then remove the lock plate.

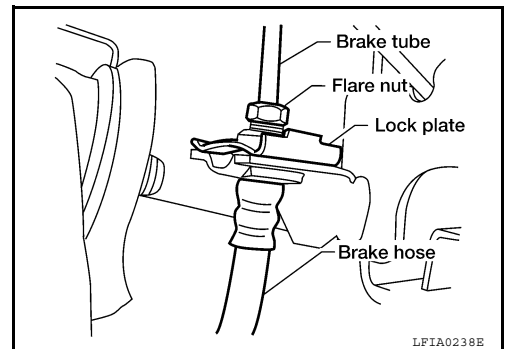

3. Remove the union bolt (A), and then remove brake hose from brake caliper assembly and discard the copper washers.

CAUTION:

Do not reuse the copper washers.

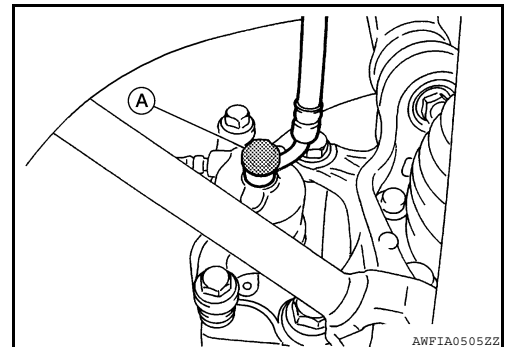

4. Remove the brake hose.

BRAKE TUBE AND HOSE

< ON-VEHICLE REPAIR >

INSTALLATION

CAUTION:

- All brake hoses and tubes must be free from excessive bending, twisting and pulling.
- Make sure that there is no interference with other parts when turning steering both clockwise and counterclockwise.
- Brake tubes and hoses are an important safety part. Always disassemble the parts and retighten their fittings, if a brake fluid leak is detected. Replace applicable part with a new one, if damaged part is detected.
- Be careful not to splash brake fluid on painted areas; it may cause paint damage. If brake fluid is splashed on painted areas, wash it away with water immediately.
- Refill with new brake fluid "DOT 3".
- Never reuse drained brake fluid.

1. Assemble the union bolt and the new copper washers on the brake hose.

CAUTION:

Do not reuse the copper washers.

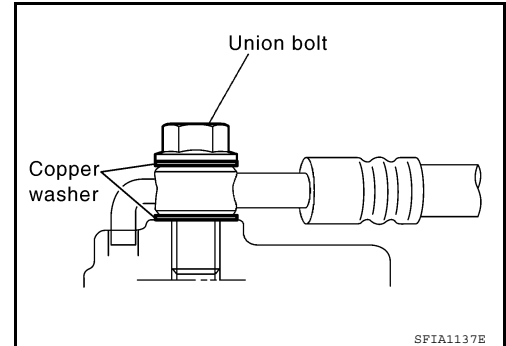

2. Attach L-shape metal fitting of the brake hose to brake caliper assembly positioning hole, and then tighten union bolt (A) to the specified torque.

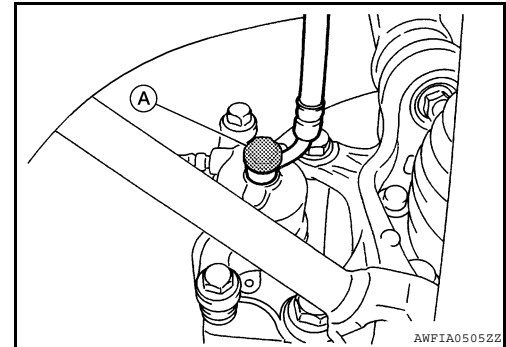

3. Connect brake hose to brake tube, partially tighten flare nut by hand as much as possible, then secure it to the bracket with lock plate.
4. Using a flare nut torque wrench, tighten flare nut to the specified torque.
5. Refill brake fluid and bleed air. Refer to [BR-14. "Bleeding Brake System"](#).

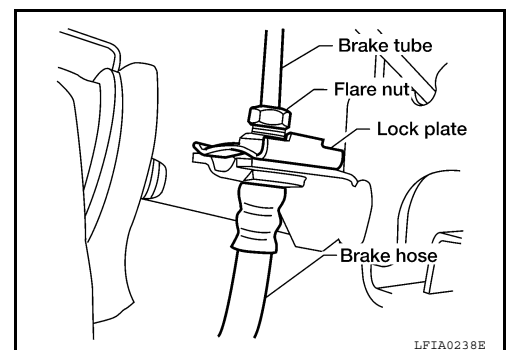

BRAKE MASTER CYLINDER

< ON-VEHICLE REPAIR >

BRAKE MASTER CYLINDER

Exploded View

INFOID:000000005440569

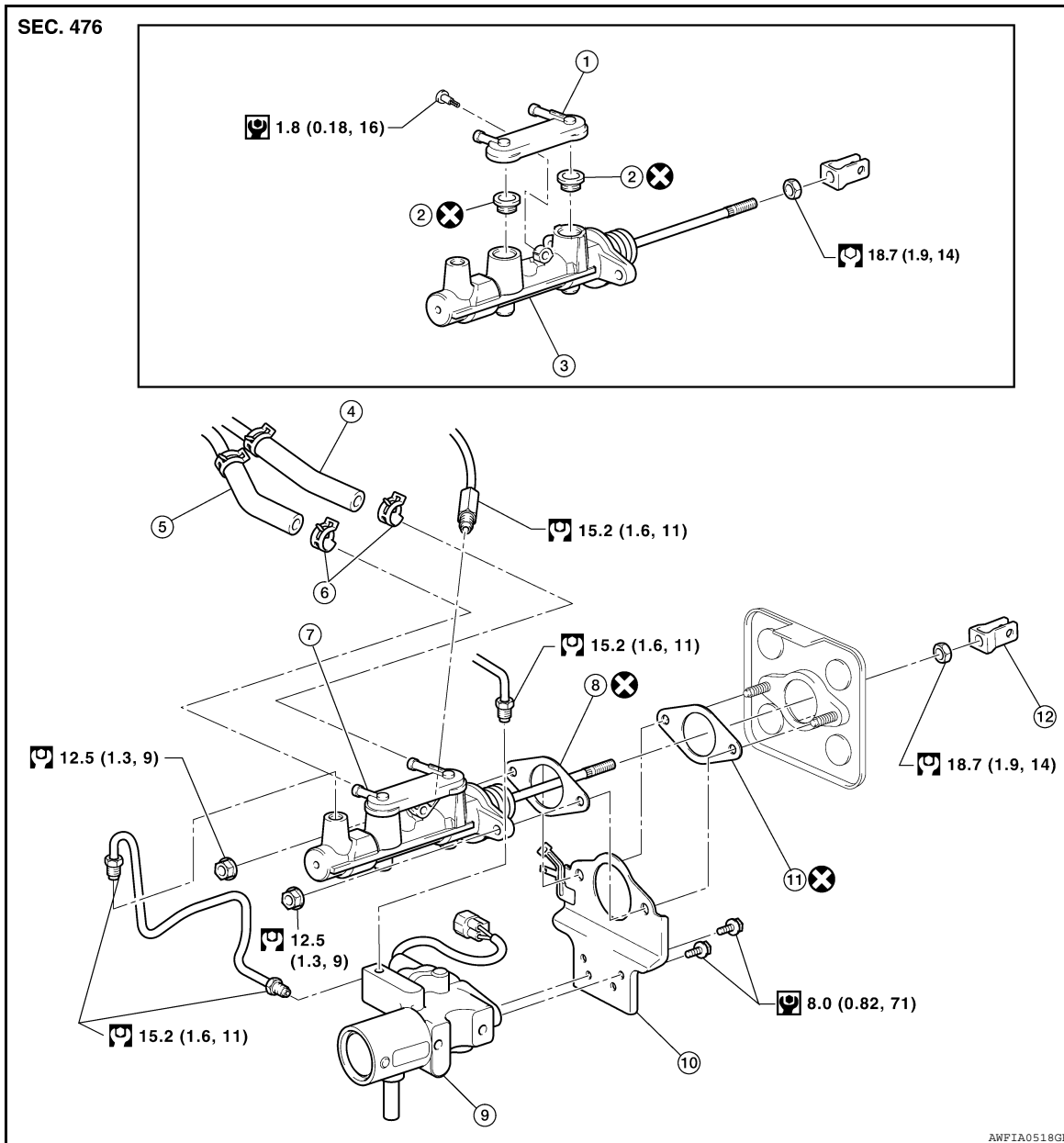

- | | | |
|---------------------------------|------------------------|---------------------------------|
| 1. Brake fluid reservoir | 2. Grommet | 3. Master cylinder sub-assembly |
| 4. Reservoir hose No.1 | 5. Reservoir hose No.2 | 6. Clamp |
| 7. Master cylinder sub-assembly | 8. Gasket | 9. Brake simulator |
| 10. Brake simulator bracket | 11. Gasket | 12. Clevis |

Removal and Installation

INFOID:000000005440570

CAUTION:

- After the work is completed, bleed air from brake simulator and brake tube.
- Do not bend or damage the brake line.
- Do not allow any foreign material such as dirt and dust from entering the brake line from the connecting points.
- Use a torque wrench with a fulcrum length of 250mm (9.84 in).
- This torque value is effective when flare nut crowfoot is parallel to a torque wrench.

BRAKE MASTER CYLINDER

< ON-VEHICLE REPAIR >

- Do not reuse gaskets.
- After replacement, adjust the brake pedal stroke sensor location to be between 0.8 and 1.2V, checking the voltage with CONSULT-III without stepping on the brake pedal. These procedures should be performed on a flat place.
- After erasing Brake ECU memories, perform zero adjustment of following sensors and initialization of linear solenoid valve. These procedures should be performed on a flat place.
- Steering angle sensor. Refer to [BRC-9, "PERFORM ZERO POINT OF STEERING ANGLE SENSOR : Description"](#).
- Yaw rate/side/decel G sensor. Refer to [BRC-8, "PERFORM ZERO POINT OF YAW RATE/SIDE/DECEL G SENSOR : Description"](#).
- Brake stroke sensor. Refer to [BRC-9, "PERFORM ADJUSTMENT OF STROKE SENSOR : Description"](#).
- Linear solenoid valve. Refer to [BRC-7, "PERFORM INITIALIZATION OF LINEAR SOLENOID VALVE AND CALIBRATION : Description"](#).

REMOVAL

1. Disconnect the mass air flow sensor, and the wiring harness retainers on the air cleaner assembly.
2. Remove the air duct hose, front air duct and air cleaner assembly. Refer to [EM-24, "Removal and Installation"](#).
3. Disconnect the brake simulator connector.
4. Disconnect the hoses and brake tubes from the brake master cylinder and brake simulator.
5. Remove the instrument lower cover (LH). Refer to [IP-10, "Exploded View"](#).
6. Remove the brake pedal clevis pin.
7. Remove the master cylinder sub-assembly nuts.
8. Pull out the master cylinder sub-assembly and remove the brake simulator with bracket.
9. Remove the brake simulator bracket bolts.
10. Remove the brake simulator from the bracket.

INSTALLATION

Installation is in the reverse order of removal.

- Bleed the brake system. Refer to [BR-14, "Bleeding Brake System"](#).

FRONT DISC BRAKE

< ON-VEHICLE REPAIR >

FRONT DISC BRAKE

BRAKE PAD

BRAKE PAD : Exploded View

INFOID:000000005440571

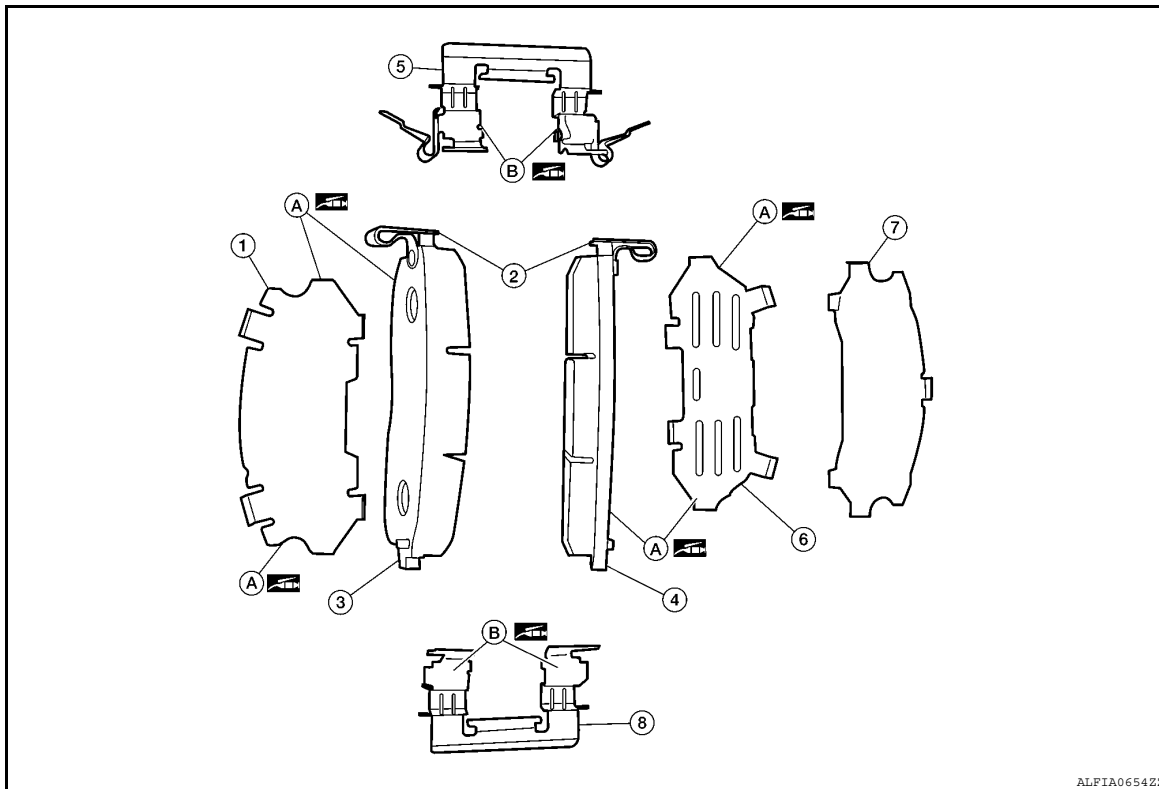

- | | | |
|----------------------------|-----------------------|----------------------------|
| 1. Inner multilayered shim | 2. Pad wear sensors | 3. Inner pad |
| 4. Outer pad | 5. Pad retainer upper | 6. Outer shim |
| 7. Outer shim cover | 8. Pad retainer lower | A. Molykote AS-880N grease |
| B. Molykote 7439 grease | | |

BRAKE PAD : Removal and Installation

INFOID:000000005440572

WARNING:

Clean dust on caliper and brake pad with a vacuum dust collector to minimize the hazard of air borne particles or other materials.

CAUTION:

- While removing caliper, do not depress brake pedal because piston will pop out.
- It is not necessary to remove bolts on torque member and brake hose except for disassembly or replacement of caliper assembly. In this case, hang caliper with a wire so as not to stretch brake hose.
- Do not damage piston boot.
- If any shim is subject to serious corrosion, replace it with a new one.
- Always replace shim and shim cover as a set when replacing brake pads.
- Keep rotor free from brake fluid.
- Burnish the brake pads and disc rotor mutually contacting surfaces, after refinishing or replacing rotors, after replacing pads, or if a soft pedal occurs at very low mileage. Refer to [BR-29, "BRAKE PAD : Brake Burnishing Procedure"](#).

REMOVAL

1. Remove the front wheel and tires. Refer to [WT-60, "Adjustment"](#).

FRONT DISC BRAKE

< ON-VEHICLE REPAIR >

2. Remove lower sliding pin bolt.

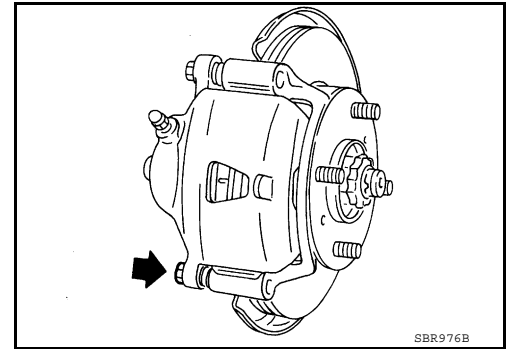

3. Hang caliper with a suitable wire, and remove pads, pad retainers, shims, and shim cover from torque member.

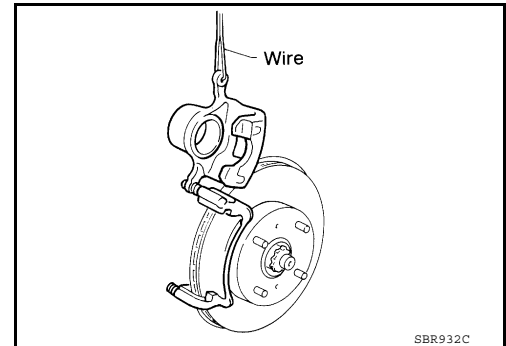

CAUTION:

When removing the pad retainer from the torque member, lift it in the direction indicated by the arrow as shown so that it does not deform.

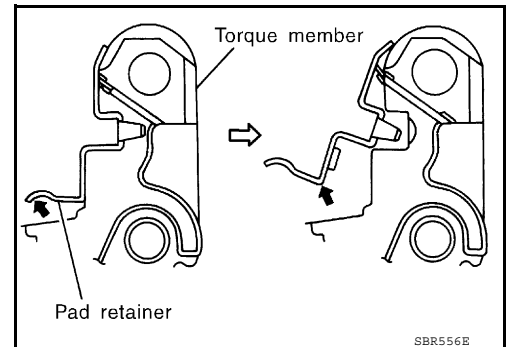

INSTALLATION

1. Apply Molykote AS-880N grease or equivalent between the caliper body fingers, outer shim cover and shim; and the inner multilayered shim and inner pad. Install outer shim, outer shim cover to outer pad, and inner multilayered shim to inner pad.
2. Apply Molykote 7439 grease or equivalent between pad retainers and pad ends. Install pad retainers and pads on torque member.

CAUTION:

- Securely assemble pad retainers so that they are not being lifted up from torque member.
- Both inner and outer pads have a pad return system on the pad retainer. Install pad return lever securely to pad wear sensor.

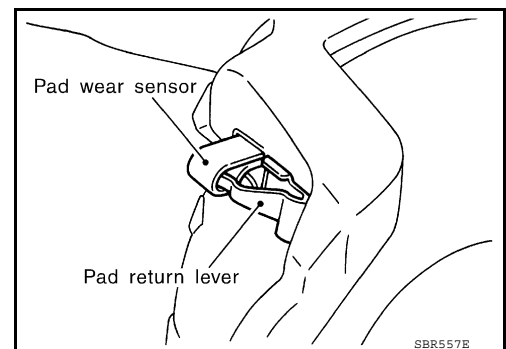

3. Install caliper over assembled pads on to the torque member.

CAUTION:

When replacing a pad with new one, check brake fluid level in the reservoir tank because brake fluid returns to master cylinder reservoir tank when pressing in the piston.

NOTE:

Use a disc brake piston tool (commercial service tool) to easily press in the piston.

FRONT DISC BRAKE

< ON-VEHICLE REPAIR >

4. Install lower sliding pin bolt, and tighten it to the specified torque. Refer to [BR-27, "BRAKE PAD : Exploded View"](#).
5. Check front disc brake for drag.
6. Install the front wheel and tires. Refer to [WT-60, "Adjustment"](#).

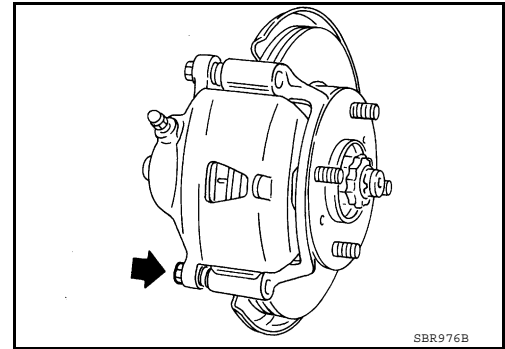

BRAKE PAD : Brake Burnishing Procedure

INFOID:000000005440573

Burnish contact surfaces between disc rotors and pads according to following procedure after refinishing or replacing rotors, after replacing pads, or if a soft pedal occurs at very low mileage.

CAUTION:

- Be careful of vehicle speed because the brake does not operate easily until pad and disc rotor are securely fitted.
 - Only perform this procedure under safe road and traffic conditions. Use extreme caution.
1. Drive vehicle on straight, flat road.
 2. Depress brake pedal with the power to stop vehicle within 3 to 5 seconds until the vehicle stops.
 3. Drive without depressing brake for a few minutes to cool the brake.
 4. Repeat steps 1 to 3 until pad and disc rotor are securely fitted.

BRAKE CALIPER ASSEMBLY

BRAKE CALIPER ASSEMBLY : Exploded View

INFOID:000000005440574

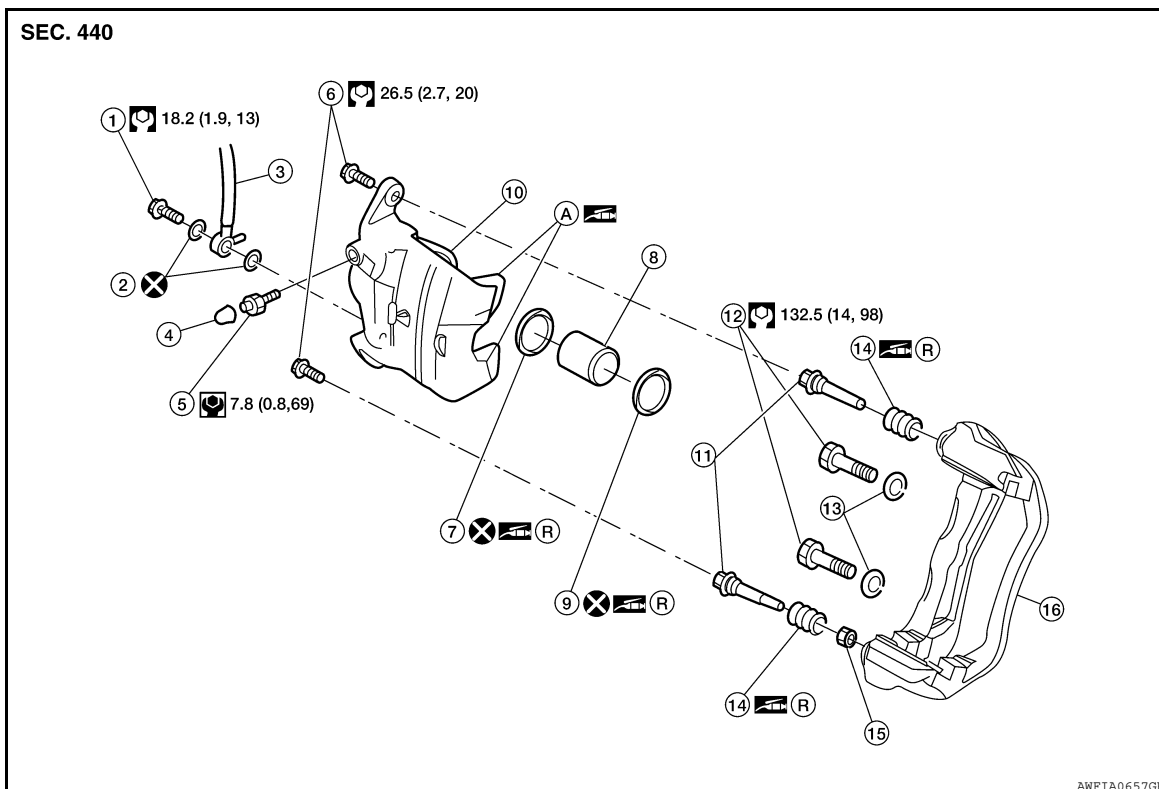

- | | | |
|----------------|------------------|------------------------|
| 1. Union bolt | 2. Copper washer | 3. Brake hose |
| 4. Cap | 5. Bleed valve | 6. Sliding pin bolt |
| 7. Piston seal | 8. Piston | 9. Piston boot |
| 10. Caliper | 11. Sliding pin | 12. Torque member bolt |

FRONT DISC BRAKE

< ON-VEHICLE REPAIR >

- | | | |
|-------------------|----------------------------|------------------|
| 13. Washer | 14. Sliding pin boot | 15. Bushing |
| 16. Torque member | A. Molykote AS-880N grease | R. Rubber grease |

BRAKE CALIPER ASSEMBLY : Removal and Installation

INFOID:000000005440575

WARNING:

Clean dust on caliper and brake pad with a vacuum dust collector to minimize the hazard of air borne particles or other materials.

CAUTION:

- While removing caliper, do not depress the brake pedal because the piston will pop out.
- Do not damage piston boot.
- Keep disc rotor free from brake fluid.
- Refill the brake reservoir with new brake fluid "DOT 3".
- Never reuse drained brake fluid.

REMOVAL

1. Remove front wheel and tires. Refer to [WT-60, "Adjustment"](#).
2. Drain brake fluid. Refer to [BR-14, "Bleeding Brake System"](#).
3. Remove union bolt (A) and disconnect brake hose from caliper assembly. Discard the copper washers.

- Protrusions (B)

CAUTION:

Do not reuse copper washers.

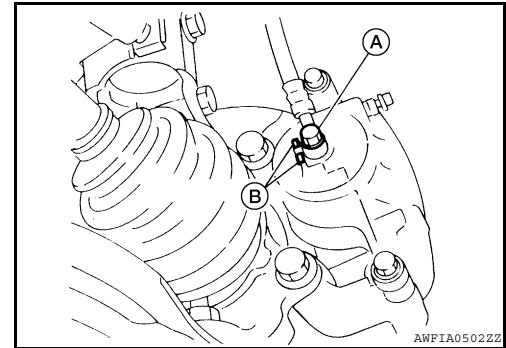

4. Remove torque member bolts, and remove brake caliper assembly.

CAUTION:

Do not drop brake pad.

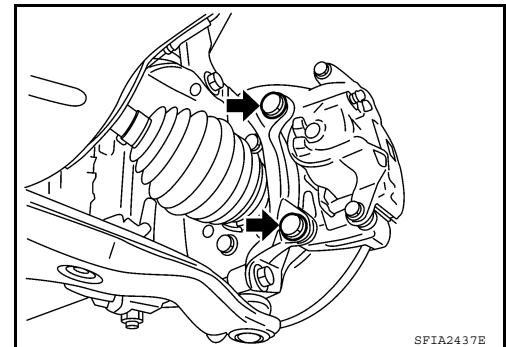

5. Remove disc rotor. If reusing the disc rotor apply matching marks as shown.

CAUTION:

Put matching marks on wheel hub assembly and disc rotor, if it is necessary to remove disc rotor.

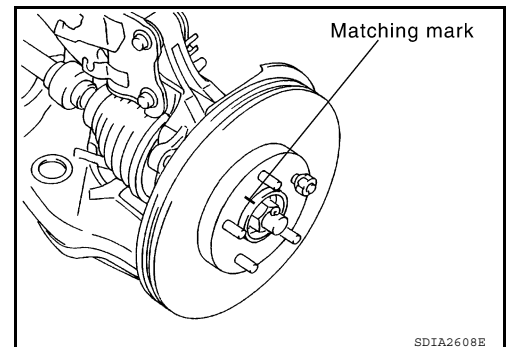

INSTALLATION

FRONT DISC BRAKE

< ON-VEHICLE REPAIR >

1. Install disc rotor, align the matching marks if installing the original disc rotor as shown.

CAUTION:

Align the marks on disc rotor and wheel hub at the time of installation when reusing disc rotor.

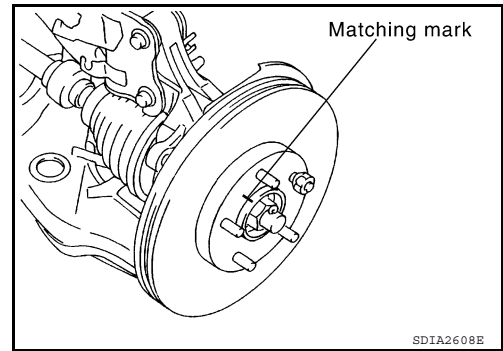

2. Install brake caliper assembly to vehicle, and tighten torque member bolts to the specified torque. Refer to [BR-29, "BRAKE CALIPER ASSEMBLY : Exploded View"](#).

CAUTION:

Do not allow oil or any moisture on all contact surfaces between steering knuckle and caliper assembly, bolts, and washer.

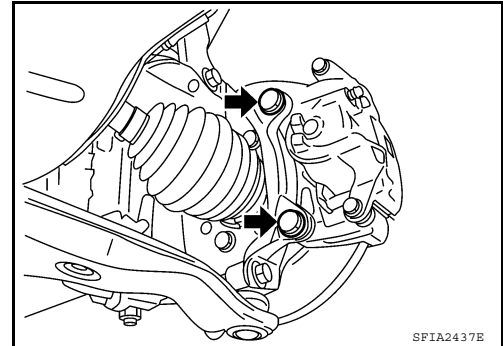

3. Install brake hose to brake caliper assembly with new copper washers. Align the brake hose tab between the protrusions (B) on the caliper assembly as shown. Tighten union bolt (A) to the specified torque. Refer to [BR-21, "FRONT BRAKE : Removal and Installation"](#).

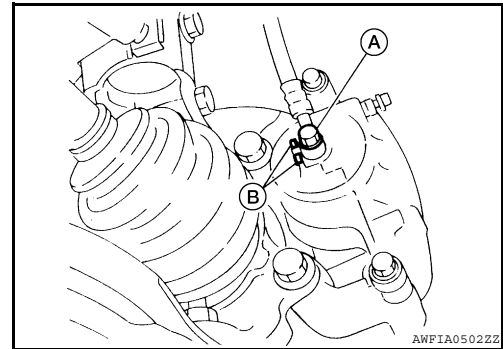

CAUTION:

Do not reuse copper washers.

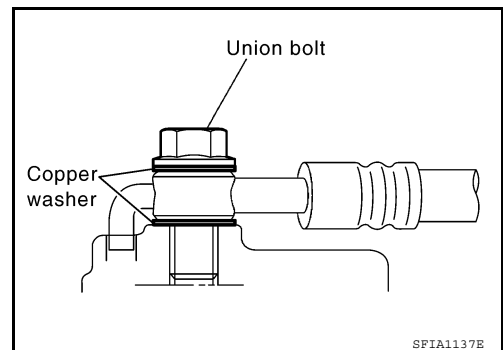

4. Refill with new brake fluid and bleed air from the brake hydraulic system. Refer to [BR-14, "Bleeding Brake System"](#).
5. Check front disc brakes for drag.
6. Install front wheel and tires. Refer to [WT-60, "Adjustment"](#).

REAR DISC BRAKE

< ON-VEHICLE REPAIR >

REAR DISC BRAKE

BRAKE PAD

BRAKE PAD : Exploded View

INFOID:000000005440576

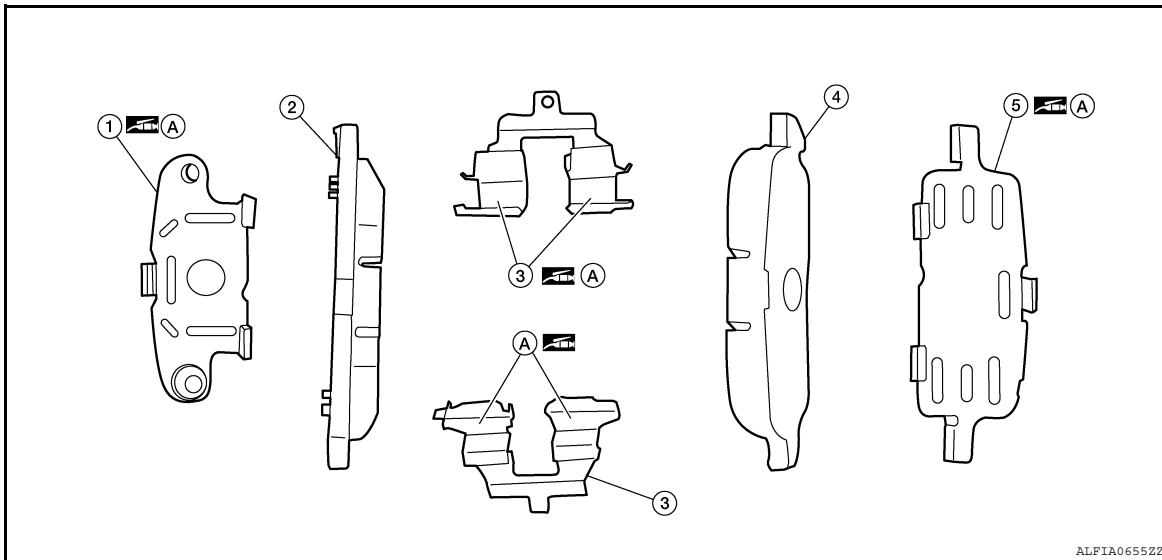

- | | | |
|----------------------------|----------------------------|----------------------------|
| 1. Inner multilayered shim | 2. Inner pad | 3. Pad retainer |
| 4. Outer pad | 5. Outer multilayered shim | A. Molykote AS-880N grease |

BRAKE PAD : Removal and Installation

INFOID:000000005440577

WARNING:

Clean dust on caliper and brake pad with a vacuum dust collector to minimize the hazard of air borne particles or other materials.

CAUTION:

- While removing caliper, do not depress brake pedal because piston will pop out.
- It is not necessary to remove bolts on torque member and brake hose except for disassembly or replacement of caliper assembly. In this case, hang caliper with a wire so as not to stretch brake hose.
- Do not damage piston boot.
- If any shim is subject to serious corrosion, replace it with a new one.
- Always replace shim and shim covers as a set when replacing brake pads.
- Keep rotor free from brake fluid.
- Burnish the brake pads and disc rotor mutually contacting surfaces after refinishing or replacing rotors, after replacing pads, or if a soft pedal occurs at very low mileage. Refer to [BR-29, "BRAKE PAD : Brake Burnishing Procedure"](#).

REMOVAL

1. Remove rear wheel and tires. Refer to [WT-60, "Adjustment"](#).
2. Remove upper sliding pin bolt (A) and swing the caliper out and support it with a suitable wire.

CAUTION:

Do not twist or stretch the brake hose.

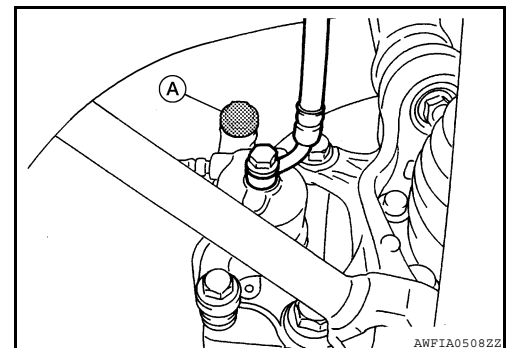

REAR DISC BRAKE

< ON-VEHICLE REPAIR >

- Remove pads, pad retainers and multilayered shims from torque member.

CAUTION:

When removing the pad retainer from the torque member, lift it in the direction indicated by the arrow as shown so that it does not deform.

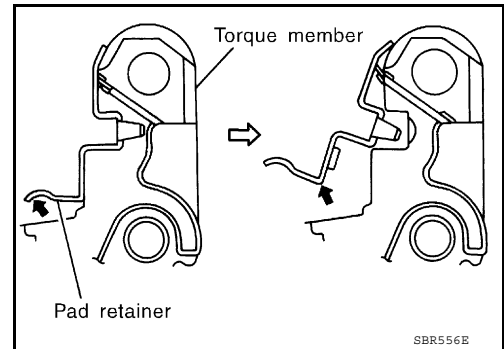

INSTALLATION

- Apply Molykote AS-880N grease or equivalent to between multilayered shims and brake pads. Install inner multilayered shim to inner pad, and outer multilayered shim to outer pad.
- Apply Molykote AS-880N grease (A) to the pad retainer as shown.

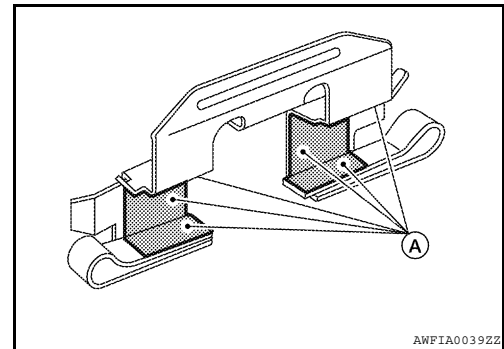

- Attach pad retainers to torque member, then install brake pads and multilayered shim assemblies.

CAUTION:

When attaching pad retainer, attach it firmly so that it is flush with torque member as shown.

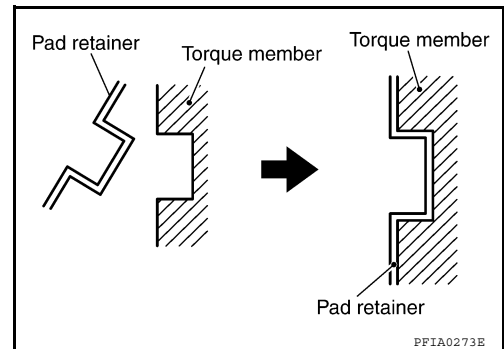

- Press in piston until pads can be installed, and then install caliper to torque member.

CAUTION:

In the case of replacing a pad with new one, check a brake fluid level in the reservoir tank because brake fluid returns to master cylinder reservoir tank when pressing piston in.

NOTE:

Use a disc brake piston tool (commercial service tool) to easily press piston.

- Install upper sliding pin bolt (A) and tighten to the specified torque. Refer to [BR-32. "BRAKE PAD : Exploded View"](#).

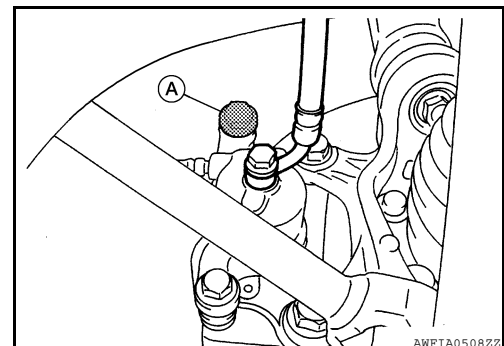

- Check rear disc brake for drag.
- Install rear wheel and tires. Refer to [WT-60. "Adjustment"](#).

REAR DISC BRAKE

< ON-VEHICLE REPAIR >

BRAKE CALIPER ASSEMBLY

BRAKE CALIPER ASSEMBLY : Exploded View

INFOID:000000005440578

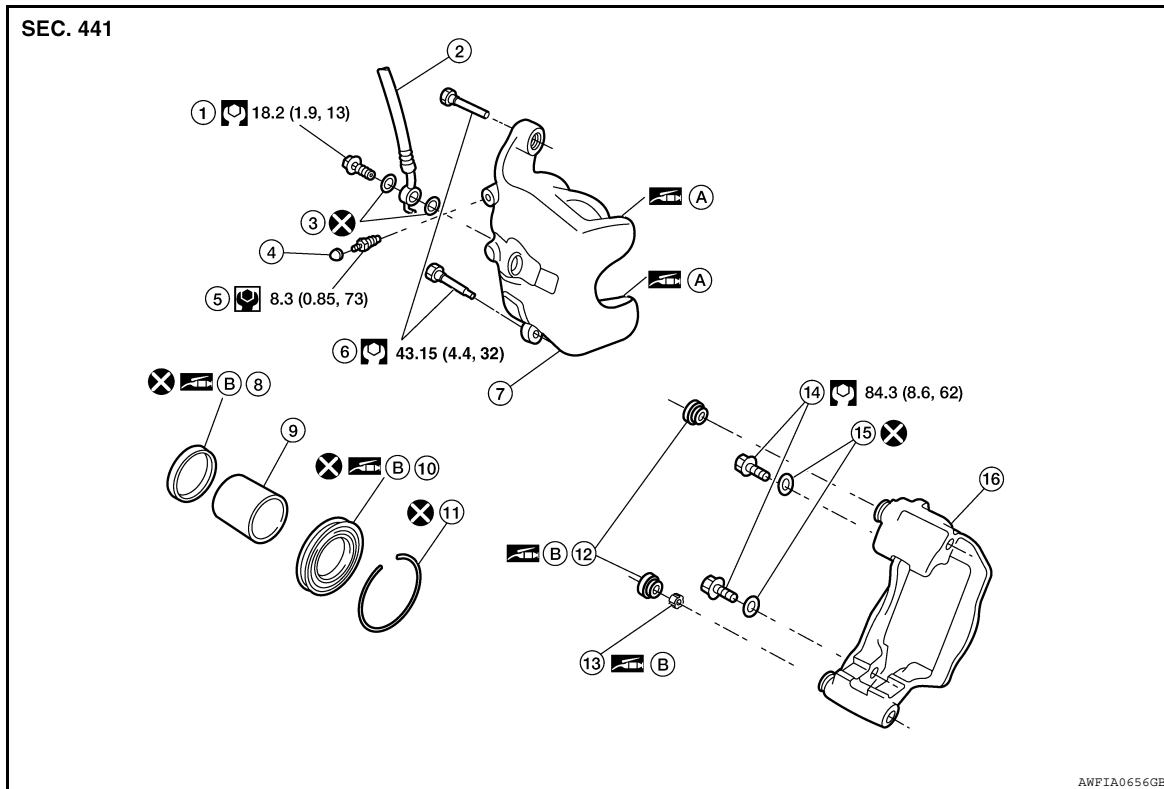

- | | | |
|-------------------|--|----------------------|
| 1. Union bolt | 2. Brake hose | 3. Copper washer |
| 4. Cap | 5. Bleed valve | 6. Sliding pin bolt |
| 7. Caliper | 8. Piston seal | 9. Piston |
| 10. Piston boot | 11. Retaining ring | 12. Sliding pin boot |
| 13. Bushing | 14. Torque member bolt | 15. Washer |
| 16. Torque member | A. PBC (Poly Butyl Cuprysil) grease or silicone-based grease | B. Rubber grease |

BRAKE CALIPER ASSEMBLY : Removal and Installation

INFOID:000000005440579

WARNING:

Clean dust on caliper and brake pad with a vacuum dust collector to minimize the hazard of air borne particles or other materials.

CAUTION:

- While removing caliper, do not depress brake pedal because the piston will pop out.
- Do not damage piston boot.
- Keep disc rotor free from brake fluid.
- Refill the brake reservoir with new brake fluid "DOT 3".
- Never reuse drained brake fluid.

REMOVAL

1. Remove rear wheel and tires. Refer to [WT-60, "Adjustment"](#).
2. Fasten disc rotor using a wheel nut.
3. Drain brake fluid. Refer to [BR-14, "Bleeding Brake System"](#).

REAR DISC BRAKE

< ON-VEHICLE REPAIR >

4. Remove union bolt (A) and disconnect the brake hose from the caliper. Discard the copper washers.

CAUTION:

Do not reuse copper washers.

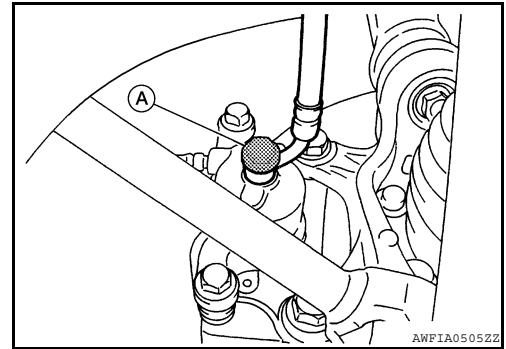

5. Remove the two torque member bolts (A), and then remove the torque member, caliper and pads as an assembly.

CAUTION:

Do not drop the brake pad and multilayered shim assemblies.

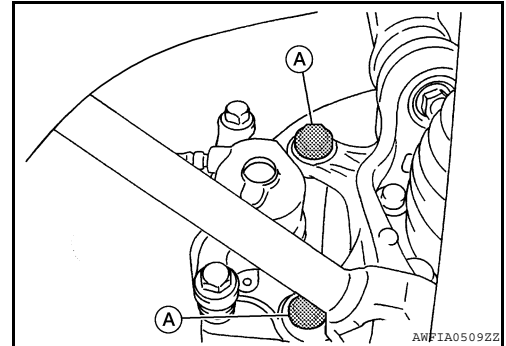

6. Remove the two sliding pin bolts and separate the caliper from the torque member. Remove the brake pad and multilayered shim assemblies from the caliper.

7. Remove the disc rotor. If reusing the disc rotor, apply matching marks as shown for installation.

CAUTION:

Put matching marks on wheel hub assembly and disc rotor, if it necessary to reuse the disc rotor.

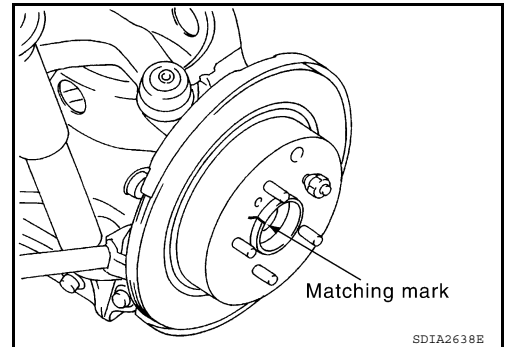

INSTALLATION

1. Install the disc rotor. If reusing the disc rotor, align the matching marks as shown.

CAUTION:

Align the matching marks on the disc rotor and wheel hub at the time of installation when reusing disc rotor.

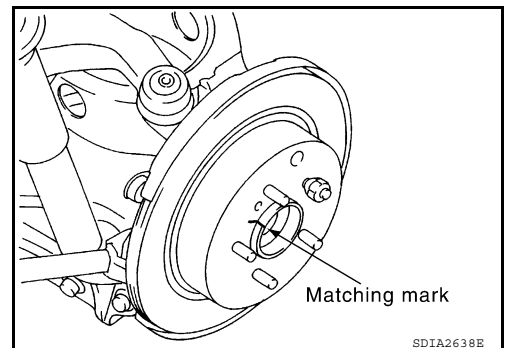

2. Install the brake pad and multilayered shim assemblies on the caliper. Refer to [BR-32. "BRAKE PAD : Exploded View"](#).
3. Install the caliper and pad assembly on the torque member, then tighten the two sliding pin bolts to the specified torque.

A
B
C
D
E
BR
G
H
I
J
K
L
M
N
O
P

REAR DISC BRAKE

< ON-VEHICLE REPAIR >

4. Install the torque member, pads and brake caliper assembly, and tighten the torque member bolts (A) to the specified torque.

CAUTION:

Before installing wipe off all oil and moisture on all mating surfaces of rear axle and torque member, threads, bolts and washers.

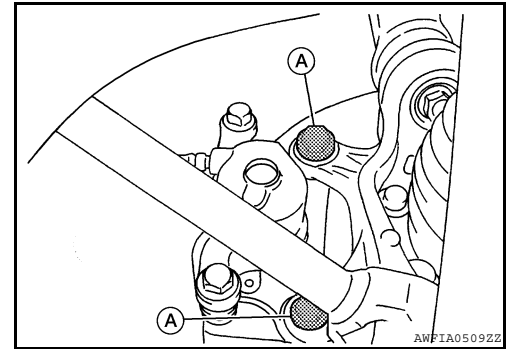

5. Align the L-shaped pin on the brake hose in the hole in the caliper, then install the brake hose with new copper washers and tighten the union bolt (A) to the specified torque. Refer to [BR-23, "REAR BRAKE : Removal and Installation"](#).

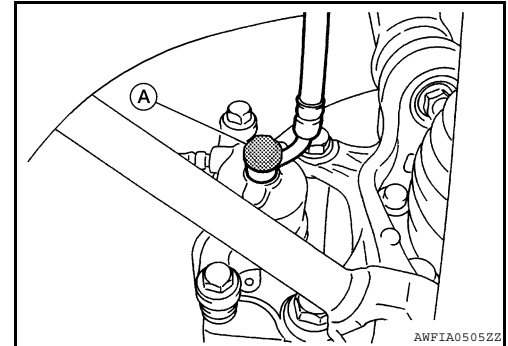

CAUTION:

Do not reuse copper washers.

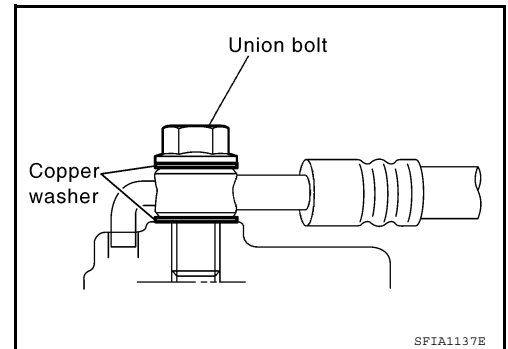

6. Refill with new brake fluid and bleed air. Refer to [BR-14, "Bleeding Brake System"](#).
7. Check rear disc brake for drag.
8. Install rear wheel and tires. Refer to [WT-60, "Adjustment"](#).

BRAKE MASTER CYLINDER

< DISASSEMBLY AND ASSEMBLY >

DISASSEMBLY AND ASSEMBLY

BRAKE MASTER CYLINDER

Exploded View

INFOID:000000005440580

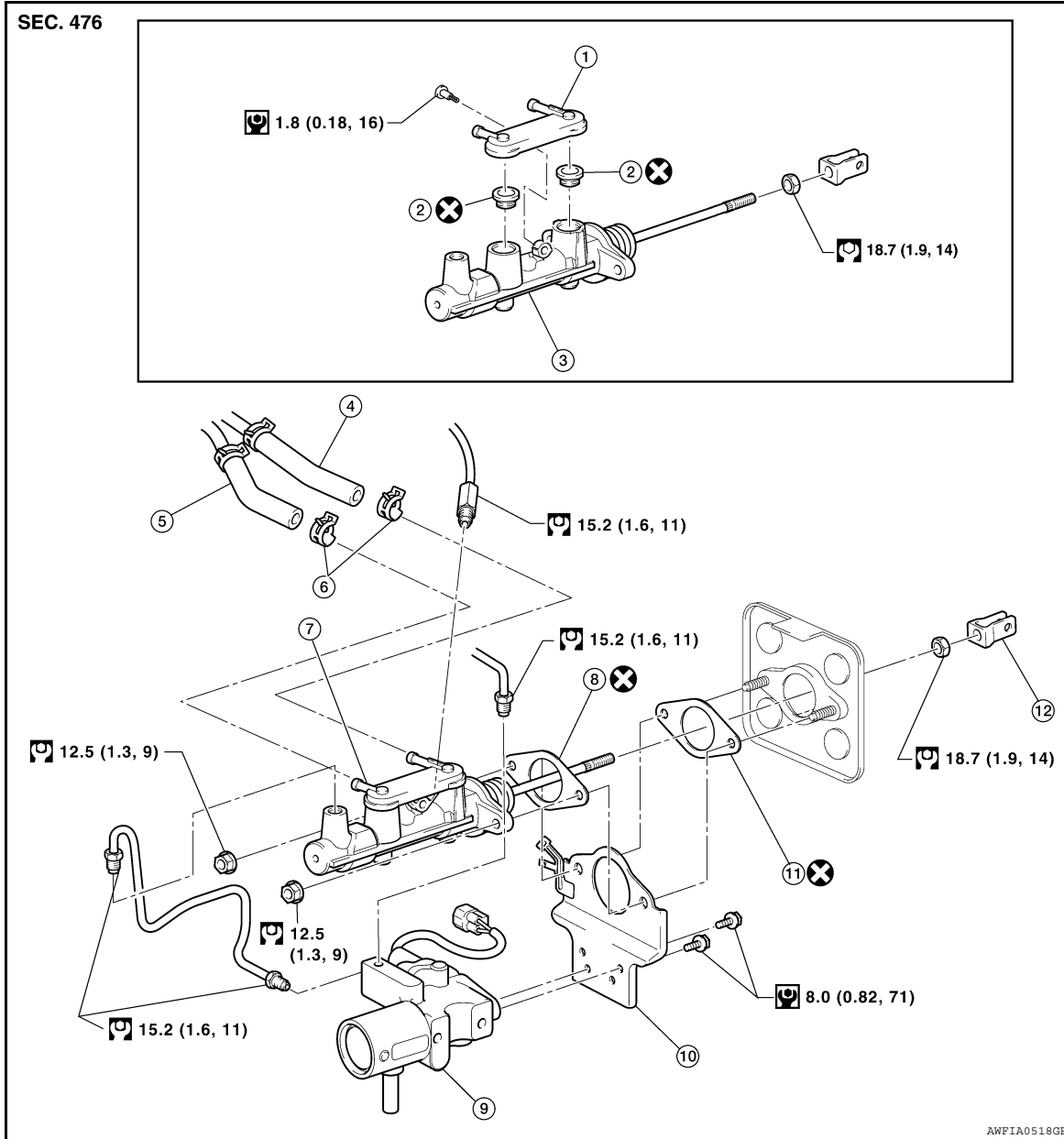

- | | | |
|---------------------------------|------------------------|---------------------------------|
| 1. Brake fluid reservoir | 2. Grommet | 3. Master cylinder sub-assembly |
| 4. Reservoir hose No.1 | 5. Reservoir hose No.2 | 6. Clamp |
| 7. Master cylinder sub-assembly | 8. Gasket | 9. Brake simulator |
| 10. Brake simulator bracket | 11. Gasket | 12. Clevis |

Disassembly and Assembly

INFOID:000000005440581

CAUTION:

- Do not reuse grommets and gaskets.
- Do not bend or damage the brake tube.
- Do not allow any foreign matter such as dirt and dust to enter the brake line from the connecting points.

BRAKE MASTER CYLINDER

< DISASSEMBLY AND ASSEMBLY >

- **Use a torque wrench with a fulcrum length of 250 mm (9.84 in).**
- **This torque value is effective when flare nut crowfoot is parallel to a torque wrench.**

DISASSEMBLY

Remove screw, brake fluid reservoir and both grommets from master cylinder sub-assembly.

ASSEMBLY

Assembly is in the reverse order of disassembly.

FRONT DISC BRAKE

< DISASSEMBLY AND ASSEMBLY >

FRONT DISC BRAKE BRAKE CALIPER ASSEMBLY

BRAKE CALIPER ASSEMBLY : Exploded View

INFOID:000000005440582

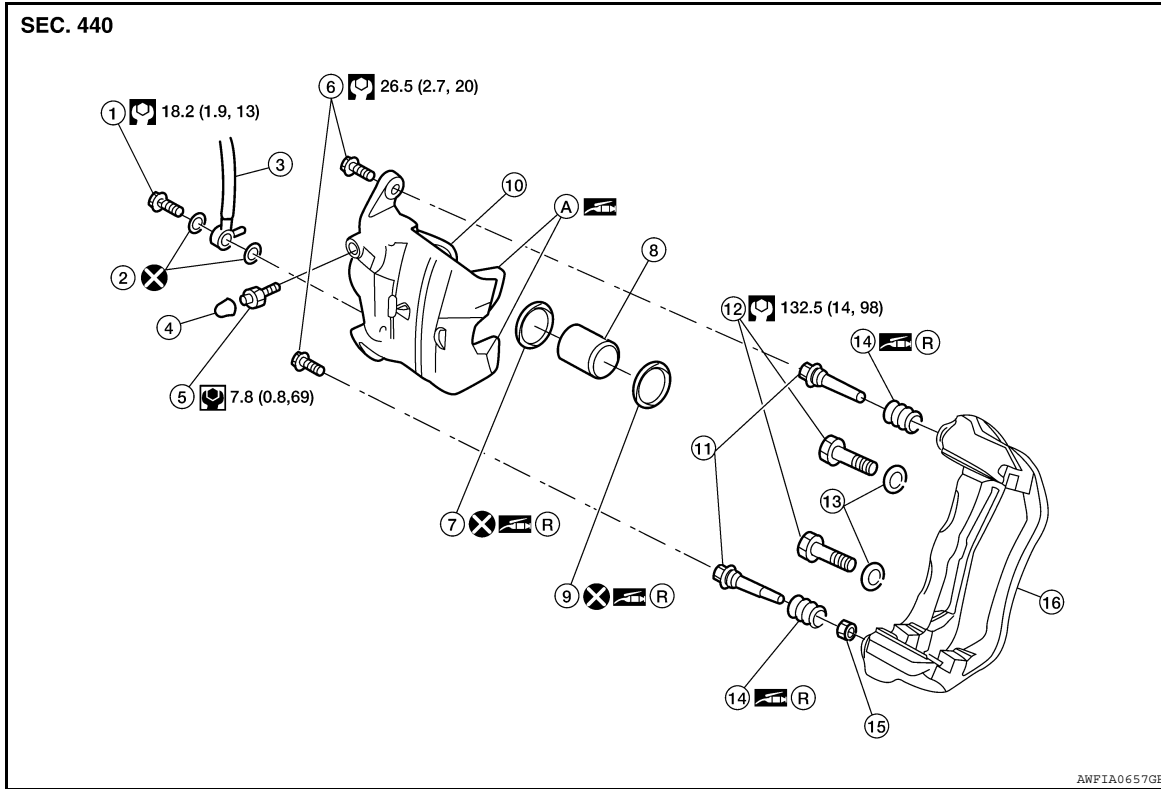

- | | | |
|-------------------|----------------------|------------------------|
| 1. Union bolt | 2. Copper washer | 3. Brake hose |
| 4. Cap | 5. Bleed valve | 6. Sliding pin bolt |
| 7. Piston seal | 8. Piston | 9. Piston boot |
| 10. Caliper | 11. Sliding pin | 12. Torque member bolt |
| 13. Washer | 14. Sliding pin boot | 15. Bushing |
| 16. Torque member | A. Molykote AS-880N | R. Rubber grease |

BRAKE CALIPER ASSEMBLY : Disassembly

INFOID:000000005440583

DISASSEMBLY

NOTE:

Do not remove the torque member, pads, multilayered shim, shim, shim cover, and pad retainers when disassembling and assembling the caliper.

- Place a wooden block in the caliper as shown, and blow air into the union bolt hole to remove the piston and piston boot.

CAUTION:

Do not get fingers caught between the piston and wooden block.

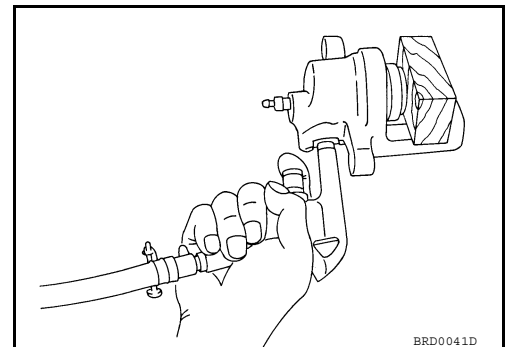

BRD0041D

FRONT DISC BRAKE

< DISASSEMBLY AND ASSEMBLY >

2. Remove the piston seal from the caliper using a suitable tool. Discard the piston seal.

CAUTION:

- Be careful not to damage a cylinder inner wall.
- Do not reuse the piston seal.

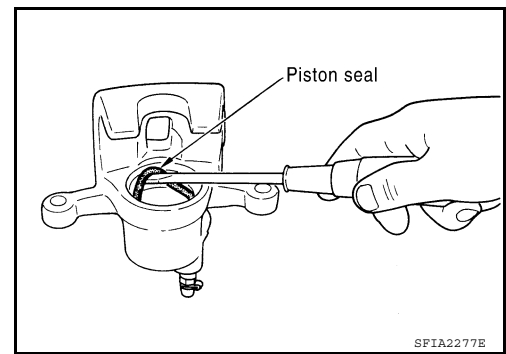

BRAKE CALIPER ASSEMBLY : Inspection After Disassembly

INFOID:000000005440584

CALIPER

Check the inner wall of caliper for corrosion, wear, and damage. Replace as necessary.

CAUTION:

Clean the caliper using new brake fluid. Never use mineral oils such as gasoline or kerosene.

TORQUE MEMBER

Check torque member for wear, cracks, and damage. Replace as necessary.

PISTON

Check the piston surface for corrosion, wear, and damage. Replace as necessary.

CAUTION:

The piston sliding surface is plated. Do not polish with sandpaper.

SLIDING PIN, SLIDING PIN BOOT, SLIDING PIN BOLT

Check the sliding pin, sliding pin bolt, and sliding pin boot for wear, damage, and cracks. Replace as necessary.

BRAKE CALIPER ASSEMBLY : Assembly

INFOID:000000005440585

ASSEMBLY

CAUTION:

Use NISSAN Rubber Grease during assembly.

1. Apply rubber grease to new piston seal, and install on caliper.

CAUTION:

Do not reuse piston seal.

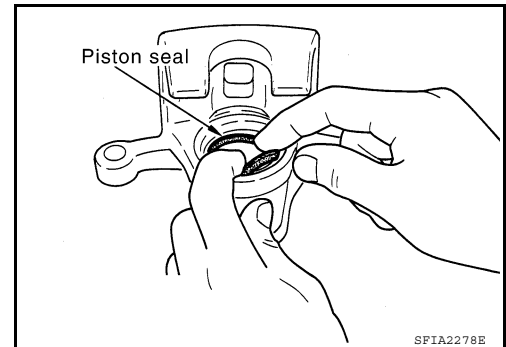

2. Apply rubber grease to new piston boot. Cover the piston end with new piston boot, and then install cylinder side lip on new piston boot securely into a groove on caliper.

CAUTION:

Do not reuse piston boot.

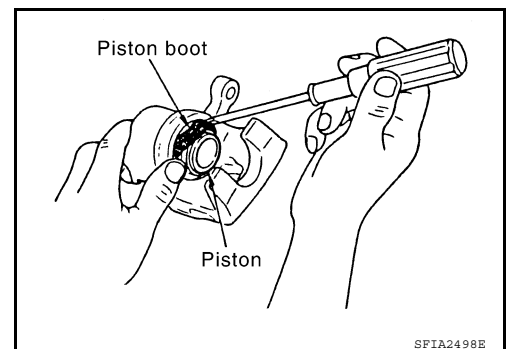

FRONT DISC BRAKE

< DISASSEMBLY AND ASSEMBLY >

3. Push piston into caliper by hand and push piston boot piston-side lip into the piston groove.

CAUTION:

Press the piston evenly and vary the pressing point to prevent cylinder inner wall from being rubbed.

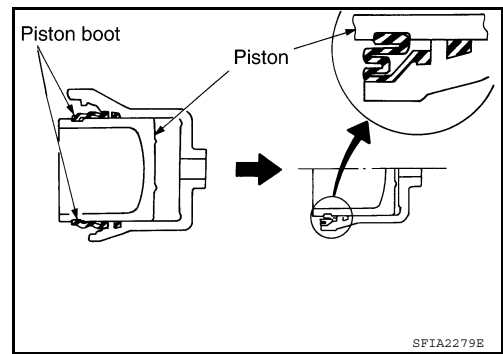

A

B

C

D

E

BR

G

H

I

J

K

L

M

N

O

P

REAR DISC BRAKE

< DISASSEMBLY AND ASSEMBLY >

REAR DISC BRAKE BRAKE CALIPER ASSEMBLY

BRAKE CALIPER ASSEMBLY : Exploded View

INFOID:000000005440586

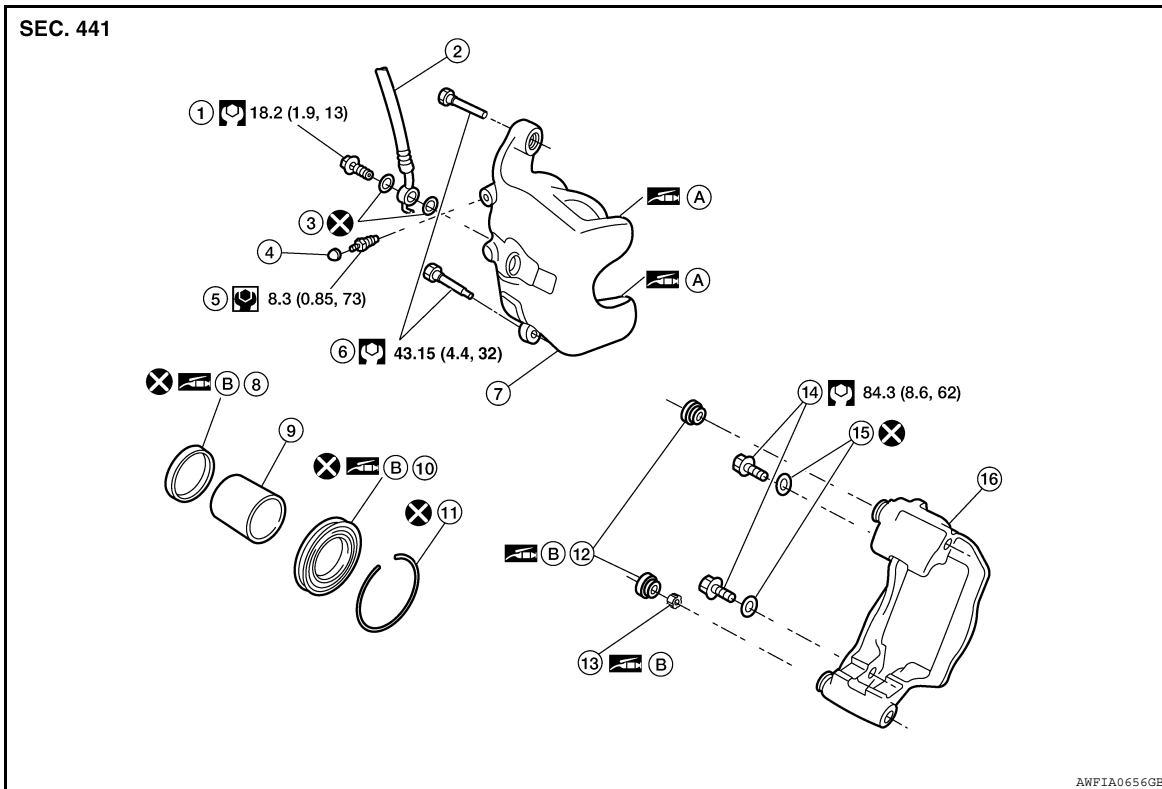

- | | | |
|-------------------|--|----------------------|
| 1. Union bolt | 2. Brake hose | 3. Copper washer |
| 4. Cap | 5. Bleed valve | 6. Sliding pin bolt |
| 7. Caliper | 8. Piston seal | 9. Piston |
| 10. Piston boot | 11. Retaining ring | 12. Sliding pin boot |
| 13. Bushing | 14. Torque member bolt | 15. Washer |
| 16. Torque member | A. PBC (Poly Butyl Cuprysil) grease or silicone-based grease | B. Rubber grease |

BRAKE CALIPER ASSEMBLY : Disassembly

INFOID:000000005440587

DISASSEMBLY

1. Remove the retaining ring from caliper using a suitable tool as shown. Discard the retaining ring

CAUTION:

Do not reuse retaining ring.

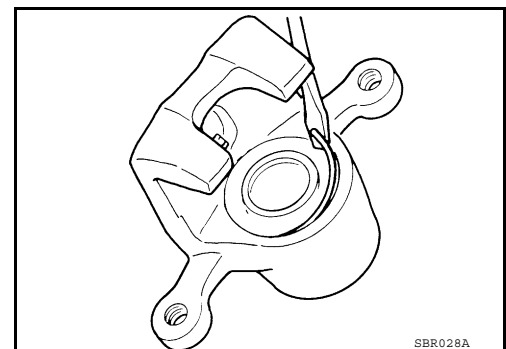

REAR DISC BRAKE

< DISASSEMBLY AND ASSEMBLY >

- Place a wooden block in the caliper as shown, and blow air into the union bolt hole to the remove piston and piston boot.

CAUTION:

Do not get fingers caught between the piston and wooden block.

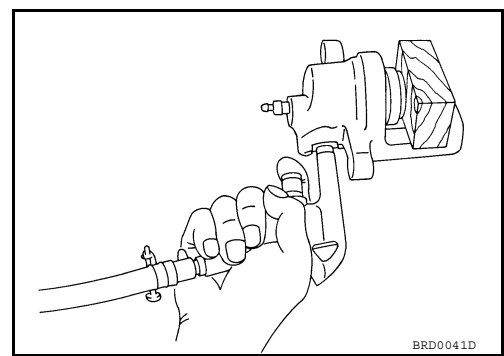

- Remove the piston seal from the caliper using a suitable tool. Discard the piston seal.

CAUTION:

- Be careful not to damage a cylinder inner wall.
- Do not reuse the piston seal.

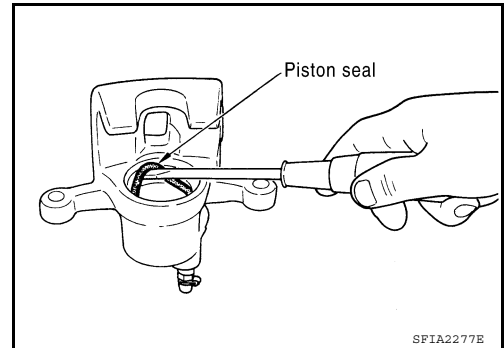

BRAKE CALIPER ASSEMBLY : Inspection After Disassembly

INFOID:000000005440588

CALIPER

Check the inner wall of the cylinder for corrosion, wear, and damage. Replace as necessary.

CAUTION:

Clean the caliper using new brake fluid. Never use mineral oils such as gasoline or kerosene.

TORQUE MEMBER

Check the torque member for wear, cracks, and damage. Replace as necessary.

PISTON

Check the piston surface for corrosion, wear, and damage. Replace as necessary.

CAUTION:

The piston sliding surface is plated. Do not polish with sandpaper.

SLIDING PIN BOLT, SLIDING PIN BOOT

Check the sliding pin bolt and sliding pin boot for wear, damage, and cracks. Replace as necessary.

BRAKE CALIPER ASSEMBLY : Assembly

INFOID:000000005440589

ASSEMBLY

CAUTION:

Use NISSAN Rubber Grease during assembly.

- Apply rubber grease to new piston seal, and install them on caliper.

CAUTION:

Do not reuse piston seal.

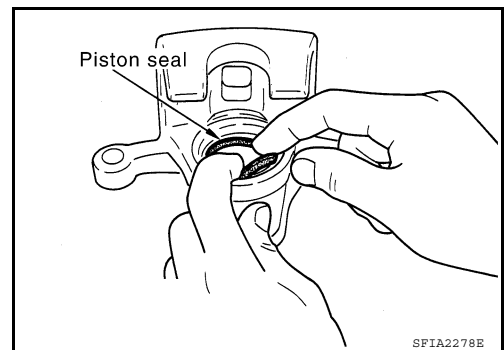

REAR DISC BRAKE

< DISASSEMBLY AND ASSEMBLY >

2. Apply rubber grease to new piston boot. Cover the piston end with the new piston boot, and then install cylinder side lip on the new piston boot securely into the groove on caliper.

CAUTION:

Do not reuse piston boot.

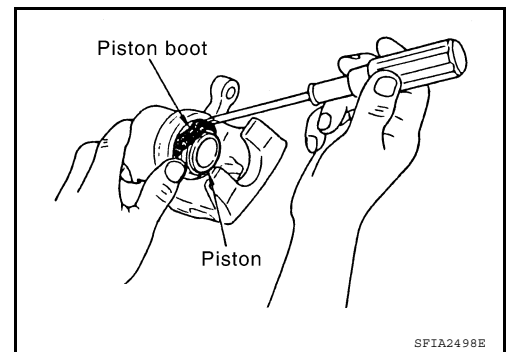

3. Push piston into caliper by hand and push piston boot piston side lip into the piston groove.

CAUTION:

Press the piston evenly and vary the pressing point to prevent cylinder inner wall from being rubbed.

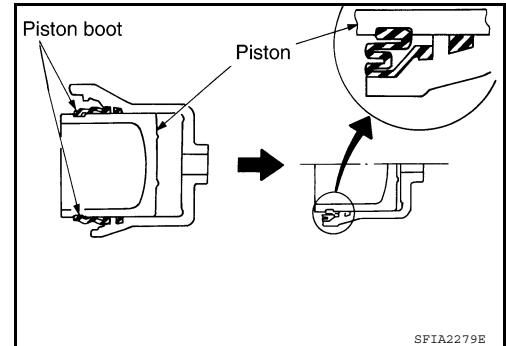

4. Secure piston boot with new retaining ring.

CAUTION:

- Make sure that boot is securely engaged in the groove on caliper.
- Do not reuse retainer ring.

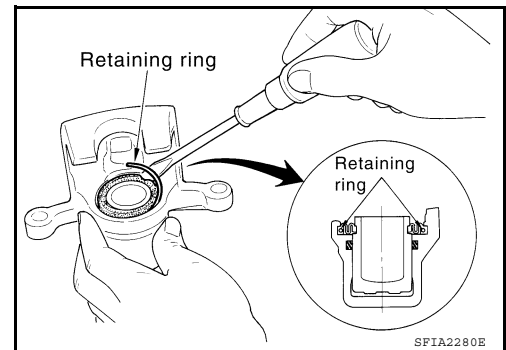

SERVICE DATA AND SPECIFICATIONS (SDS)

< SERVICE DATA AND SPECIFICATIONS (SDS)

SERVICE DATA AND SPECIFICATIONS (SDS)

SERVICE DATA AND SPECIFICATIONS (SDS)

General Specifications

INFOID:000000005440590

Unit: mm (in)

Front brake	Cylinder bore diameter (each)	57.2 (2.25)
	Pad length × width × thickness	126.5 × 52 × 11 (4.98 × 2.047 × 0.433)
	Rotor outer diameter × thickness	296 × 26 (11.65 × 1.024)
Rear brake	Cylinder bore diameter	34.93 (1.375)
	Pad length × width × thickness	83 × 33 × 8.5 (3.268 × 1.299 × 0.335)
	Rotor outer diameter × thickness	292 × 9 (11.50 × 0.354)
Recommended brake fluid		DOT 3

Brake Pedal

INFOID:000000005440591

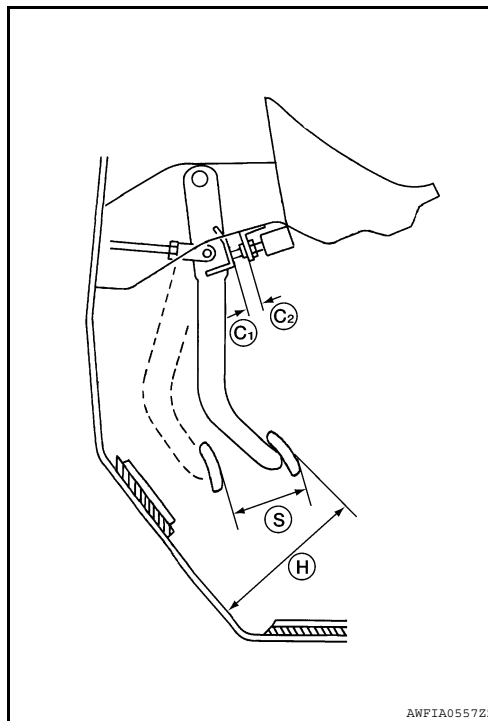

H	Brake pedal height (from dash lower panel top surface)	191.7 - 205.7 mm (7.55 - 8.10 in)
S	Brake pedal full stroke	130 mm (5.12 in)
C1, C2	Clearance between bracket and threaded end of the stop lamp switch and ASCD cancel switch	0.74 - 1.96 mm (0.0291 - 0.0772 in)

Front Disc Brake

INFOID:000000005440592

Brake pad	Standard thickness (new)	11.0 mm (0.433 in)
	Wear limit thickness	2.0 mm (0.079 in)
Disc rotor	Standard thickness (new)	26.0 mm (1.024 in)
	Wear limit thickness	24.0 mm (0.945 in)
	Thickness variation (measured at 8 positions)	0.015 mm (0.0006 in)
	Maximum runout (with it attached to the vehicle)	0.040 mm (0.0016 in)

SERVICE DATA AND SPECIFICATIONS (SDS)

< SERVICE DATA AND SPECIFICATIONS (SDS)

Rear Disc Brake

INFOID:000000005440593

Brake pad	Standard thickness (new)	8.5 mm (0.335 in)
	Wear limit thickness	1.0 mm (0.039 in)
Disc rotor	Standard thickness (new)	9.0 mm (0.354 in)
	Wear limit thickness	8.0 mm (0.315 in)
	Thickness variation (measured at 8 positions)	0.015 mm (0.0006 in)
	Maximum runout (with it attached to the vehicle)	0.05 mm (0.0020 in)